

Knife Gate Valve

HERA-BDS

PN 10/16, Class 150
DN 50-600
Bi-directional
Full-lug Body

Type Series Booklet



Legal information/Copyright

Type Series Booklet HERA-BDS

All rights reserved. The contents provided herein must neither be distributed, copied, reproduced, edited or processed for any other purpose, nor otherwise transmitted, published or made available to a third party without the manufacturer's express written consent.

Subject to technical modification without prior notice.

© KSB Aktiengesellschaft, Frankenthal 07.10.2015

Knife Gate Valves

Bi-directional knife gate valve

HERA-BDS



Main applications

- Mining
- Sewage treatment plants
- Paper and cellulose industry
- Cement plants
- Chemical industry

Fluids handled

- Slurry
- Abrasive fluids
- Pulp
- Waste water
- Service water
- Other fluids on request.

Operating data

Operating properties

Characteristic	Value
Nominal pressure	PN 10/16, Class 150
Nominal size	DN 50-600
Max. permissible pressure	10 bar
Max. permissible temperature	120 °C

Body materials

Overview of available materials

Material	Temperature limit
ASTM A 216 WCB	Up to 425 °C
ASTM A 351 CF8	Up to 538 °C
ASTM A 351 CF8M	Up to 538 °C

Other materials on request.

Design details

Design

- Design to ASME B16.34 and MSS SP-81
- Pressure/temperature ratings to MSS SP-81
- Full-lug body
- Wafer-type body
- Bi-directional seal
- Rising stem
- Non-rising handwheel
- Resilient lining
- The valves satisfy the safety requirements of Annex I of the European Pressure Equipment Directive 97/23/EC (PED) for fluids in Group 2.

Variants

- Non-rising stem
- Graphite gland packing for high temperatures
- Locking device
- Protection plate
- Mounting of electric and pneumatic actuators
- Mounting of gearboxes
- Other material variants
- Larger nominal sizes up to DN 900

Product benefits

- Blade bottom edge curved for high cutting force. Smooth blade surface due to precision grinding and hard chromium plating, for increased abrasion resistance and long service life.
- Internal gland packing with improved sealing performance
- Two-piece body designed without dead volumes to prevent pulp deposits inside the body and jamming of the blade, particularly in the case of solids-laden fluids.
- Long service life due to resilient, abrasion-resistant die-cast rubber seat with metal backing ring Replaceable seats, easy to remove and install
- Drain facility at the bottom of the valve body. Body bottom dismantles easily for regular cleaning. Flushing system can be fitted by customer.

Related documents

- Operating manual 7332.8

On all enquiries/orders please specify

- | | |
|--|---|
| <ol style="list-style-type: none"> 1. Type 2. Nominal pressure 3. Nominal size 4. Operating pressure 5. Operating temperature 6. Line connection | <ol style="list-style-type: none"> 7. Material 8. Fluid handled 9. Variants 10. Number of type series booklet <p>Always indicate the original serial number and the year of construction when ordering spare parts.</p> |
|--|---|

Pressure/temperature ratings

Test and operating pressures

Nominal pressure	Nominal size	Shell test ¹⁾²⁾	Leak test (seat) ¹⁾	Permissible operating pressures
		with water		
PN	DN	[bar]	[bar]	[bar]
10	50-600	15	2,8	10,3
16	50-600	24	2,8	10,3
Class 150	50-600	30	2,8	10,3

Materials

HERA-BDS with handwheel

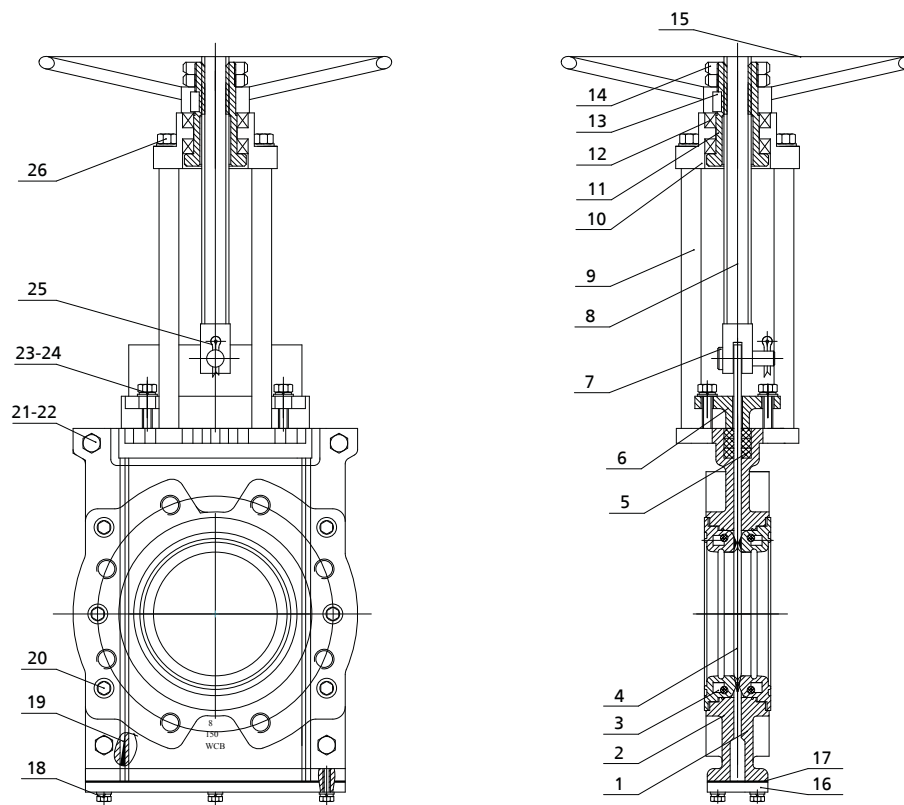

Overview of available materials

Part No.	Description	Material	Note
1	Upper body section	ASTM A 216 WCB	
		ASTM A 351 CF8	

1) Test procedure to MSS SP-81
2) Test medium at 0 °C to 66 °C

Part No.	Description	Material	Note
		ASTM A 351 CF8M	
2	Lower body section	ASTM A 216 WCB	
		ASTM A 351 CF8	
		ASTM A 351 CF8M	
3	Seat	EPDM	
		NBR	
		Rubber	
4	Blade	ASTM A 182 F304	Hard chromium plated
		ASTM A 182 F316	Hard chromium plated
		ASTM A 276 410	Material available for model with metal (hard chromium plated) seat only
5	Packing ring	PTFE	
6	Gland follower	ASTM A 216 WCB	
		ASTM A 351 CF8	
		ASTM A 351 CF8M	
7	Pin	ASTM A 182 F304	
8	Stem	ASTM A 182 F304	
9	Pillar	ASTM A 182 F304	Body made of A 351 CF8(M)
		C45 + Cr	Body made of A 216 WCB
10	Cover	ASTM A 216 WCB	
		ZL102	
11	Nut	H59	
12	Plain bearing	GCr6	
13	Key	45#	
14	Slotted round nut	45#	Electroless nickel-plated
15	Handwheel	Nodular cast iron	
16	Bottom	ASTM A 216 WCB	
		ASTM A 351 CF8	
		ASTM A 351 CF8M	
17	Gasket	NBR	
18	Hexagon head bolt	ASTM A 182 F304	
19	Sealing cord	NBR	
20	Hexagon socket head cap screw	ASTM A 182 F304	
21	Hexagon head bolt	ASTM A 182 F304	
22	Hexagon nut	ASTM A 182 F304	
23	Stud	ASTM A 182 F304	
24	Hexagon nut	ASTM A 182 F304	
25	Split pin	Stainless steel	
26	Hexagon nut	ASTM A 182 F304	

HERA-BDS with pneumatic actuator

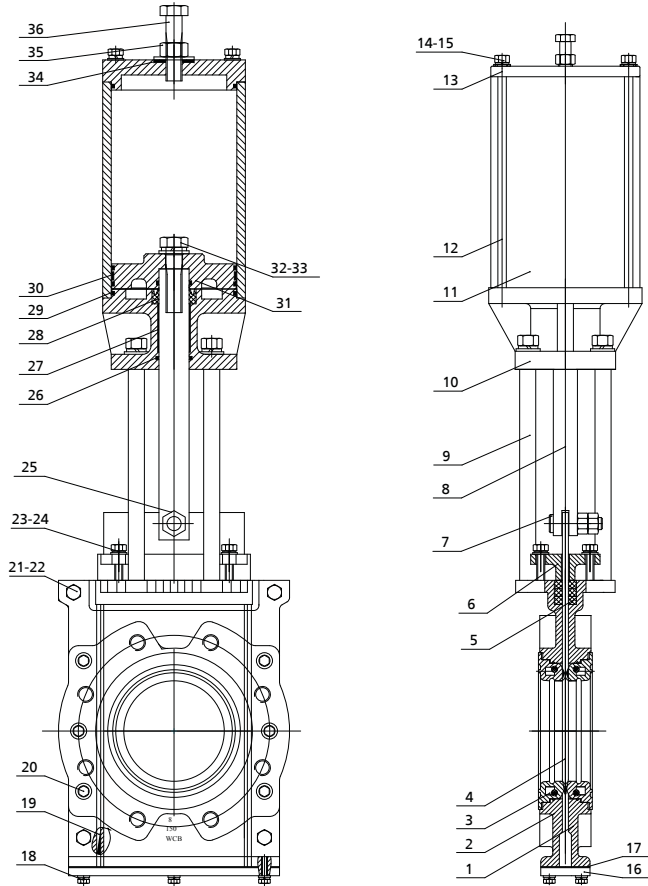

Overview of available materials

Part No.	Description	Material	Note
1	Upper body section	ASTM A 216 WCB	
		ASTM A 351 CF8	
		ASTM A 351 CF8M	
2	Lower body section	ASTM A 216 WCB	
		ASTM A 351 CF8	
		ASTM A 351 CF8M	
3	Seat	EPDM	
		NBR	
		Rubber	
4	Blade	ASTM A 182 F304	Hard chromium plated
		ASTM A 182 F316	Hard chromium plated
		ASTM A 276 410	Material available for model with metal (hard chromium plated) seat only
5	Packing ring	PTFE	
6	Gland follower	ASTM A 216 WCB	
		ASTM A 351 CF8	
		ASTM A 351 CF8M	
7	Pin	ASTM A 182 F304	
8	Cylinder rod	45#	Hard chromium plated
9	Pillar	ASTM A 182 F304	Body made of A 351 CF8(M)
		C45 + Cr	Body made of A 216 WCB
10	Bottom end cap	Q 235	
		ZL102	
11	Cylinder	Q 235	Aluminium alloy
12	Tie bolt	Q 235	Galvanised

Part No.	Description	Material	Note
13	Top end cap	Q 235	
		ZL102	
14	Hexagon nut	ASTM A 182 F304	
15	Spring washer	65Mn	
16	Bottom	ASTM A 216 WCB	
		ASTM A 351 CF8	
		ASTM A 351 CF8M	
17	Gasket	NBR	
18	Hexagon head bolt	ASTM A 182 F304	
19	Sealing cord	NBR	
20	Hexagon socket head cap screw	ASTM A 182 F304	
21	Hexagon head bolt	ASTM A 182 F304	
22	Hexagon nut	ASTM A 182 F304	
23	Stud	ASTM A 182 F304	
24	Hexagon nut	ASTM A 182 F304	
25	Hexagon nut	ASTM A 182 F304	
26	O-ring	NBR	
27	Boundary-lubricated bearing	Composite	
28	Y-ring	Polyurethane	
29	O-ring	NBR	
30	Guide ring	PTFE	
31	Piston	ZL102	
		Q 235	
32	Hexagon head bolt	45#	
33	Spring washer	65Mn	
34	Gasket	PTFE	
35	Hexagon nut	ASTM A 182 F304	
36	Adjusting screw	ASTM A 182 F304	

Dimensions

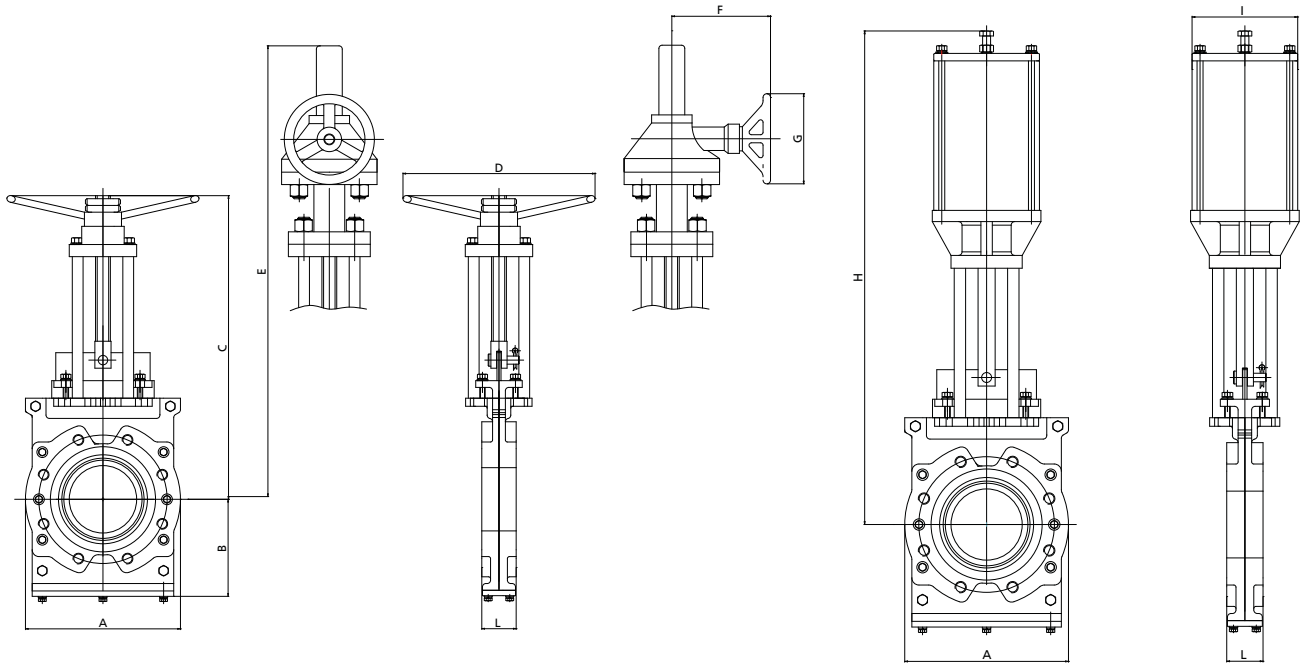

Dimensions in mm

DN	L	A	B	C ³⁾	E ³⁾	D	F	G	H	I	With handwheel	With gearbox	With pneumatic actuator
											[kg]	[kg]	[kg]
50	48	165	120	450/360	-	220	-	-	550	120	20	-	26
65	48	190	130	475/390	-	220	-	-	600	120	22	-	30
80	51	200	145	535/415	-	220	-	-	640	120	26	-	35
100	51	230	150	600/450	-	250	-	-	700	145	35	-	42
125	57	230	180	690/510	-	250	-	-	840	190	38	-	50
150	57	285	200	740/550	-	282	-	-	910	190	42	-	66
200	70	345	220	885/660	-	355	-	-	1100	225	65	-	87
250	70	405	275	1060/780	-	355	-	-	1280	225	85	-	140
300	76	485	330	-	1450/1105	-	260	310	1440	282	-	162	225
350	76	535	350	-	1570/1160	-	260	310	1700	330	-	190	298
400	89	600	380	-	1670/1220	-	260	310	1855	410	-	230	335
450	89	635	400	-	1800/1230	-	340	460	2000	500	-	290	395
500	114	705	450	-	1950/1790	-	340	460	2180	550	-	360	470
600	114	820	510	-	1890/2490	-	340	460	2400	650	-	440	570

Mating dimensions – Standards

Face-to-face MSS SP-81

lengths:

Flanges: Mating dimensions Class 150: ANSI B 16.5
Mating dimensions PN 10, PN 16: DIN 2501

³⁾ (Fully open/closed)



KSB Aktiengesellschaft

Johann-Klein-Straße 9 • 67227 Frankenthal (Germany)

Tel. +49 6233 86-0 • Fax +49 6233 86-3476

E-Mail: valves@ksb.com • www.ksb.com

07.10.2015

7332.1/03-EN