

Deep Well Turbine Pump B

1. Application

Deep Well Turbine (DWT) B Pumps are suitable for water supply schemes, irrigation schemes, lowering of ground water level and dewatering of mines, quarries and construction sites. These are particularly suitable for narrow bore holes.

2. Design

Main pump parts are the Pump Bowl Assembly, Column Pipe Assembly, and Discharge Head Assembly. Bowl Assembly consists of single or multistage radially split, interchangeable intermediate bowls. Column Pipe Assembly consists of interchangeable lengths of the column pipes and variable setting depth. Discharge head assembly consists of discharge head with packed stuffing zone / mechanical seal and thrust bearing arrangement (in case of solid shaft drive only).

3. Designation

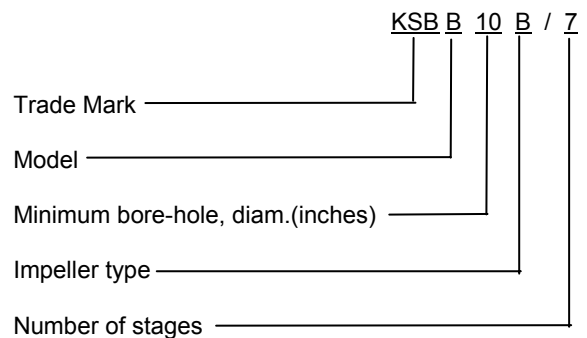

4. Operating Data

Size	- DN 6" up to 24"
Flow	- up to 8806 gpm (2000 m ³ /h)
Total head	- up to 984 ft (300 m)
Temperature	- up to 176° F (80° C)
Max.discharge pressure	- 284 Lb/in ² (20 Kgf/cm ²)
Speed	- 3500 rpm

5. Selection chart 60 Hz

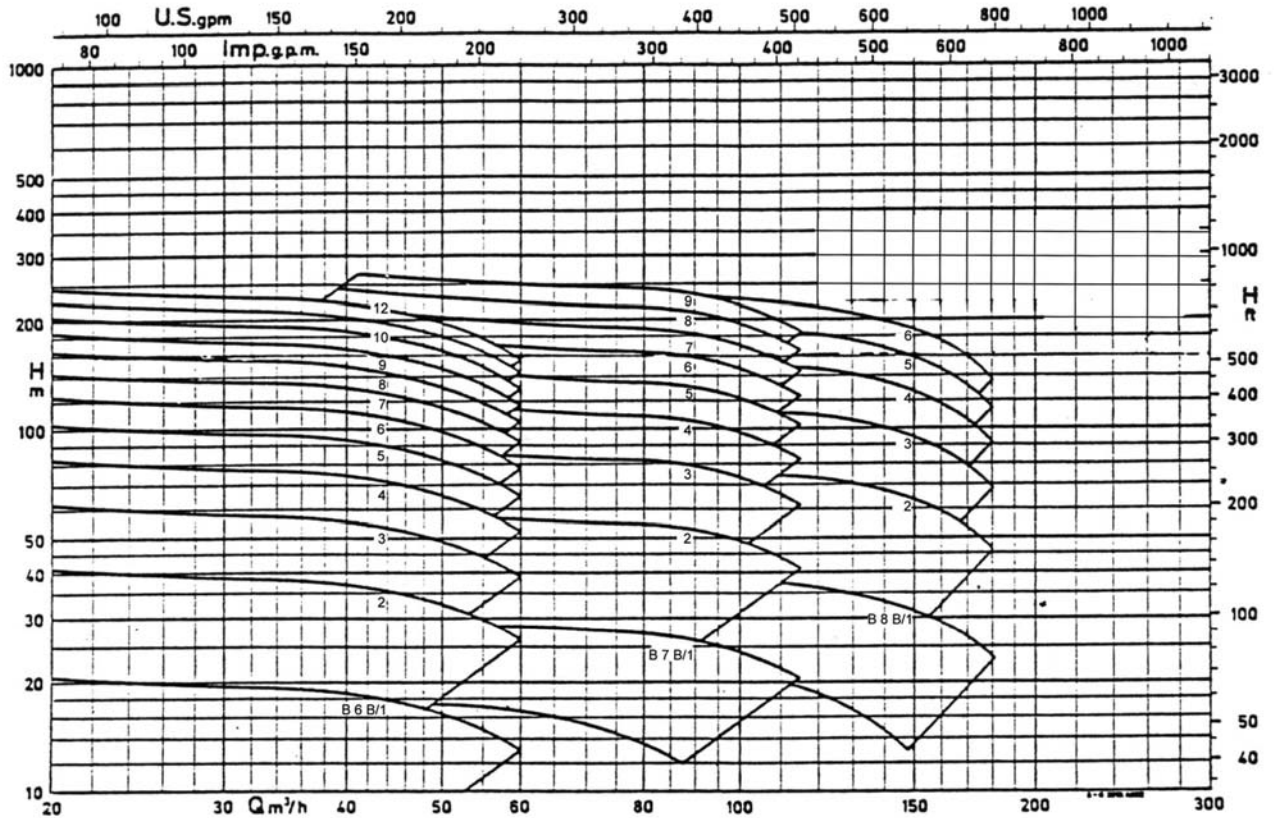

Fig 1 – B6B / B7B / B8B – n = 3480 rpm

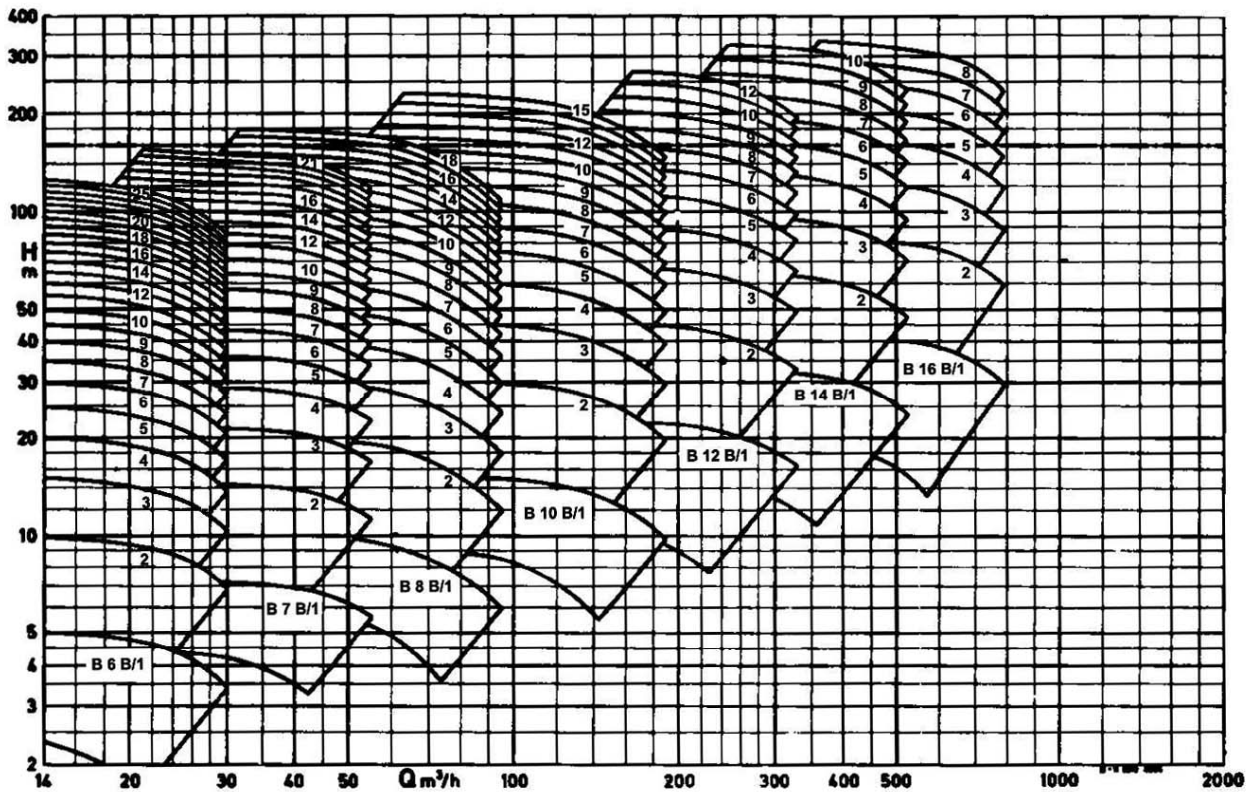

Fig 2 – B6B up to B16B – n = 1740 rpm

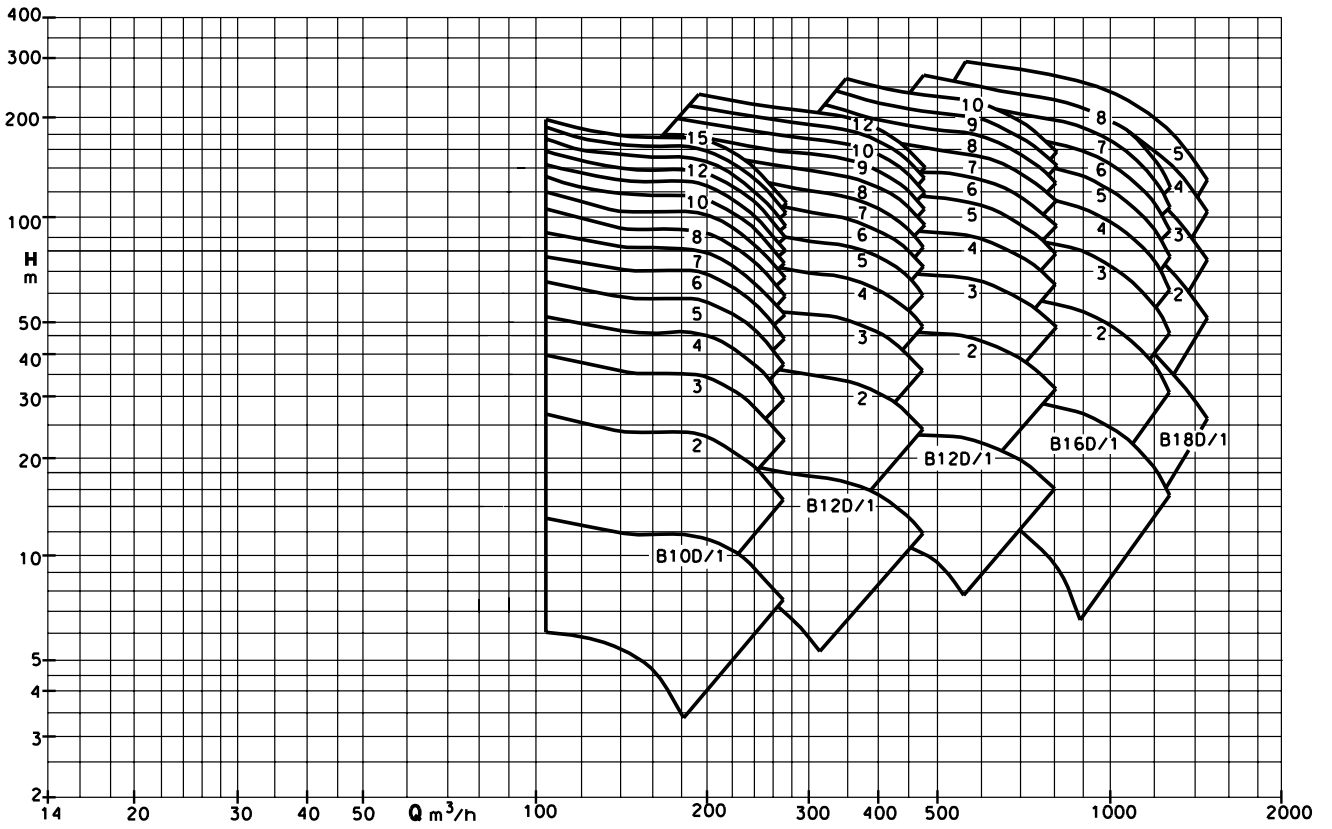

Fig 3 – B10D up to B18D - $n = 1740$ rpm

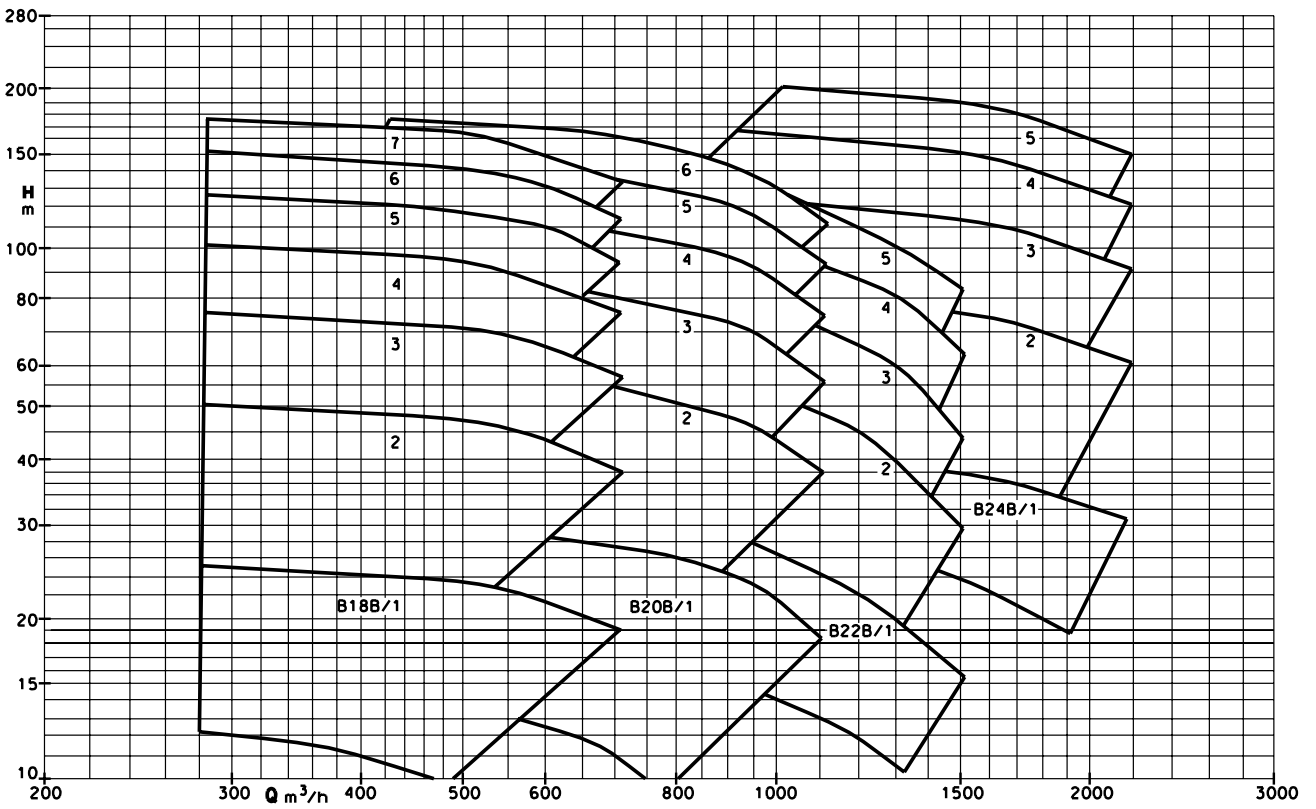

Fig. 4 – B18B up to B24B - $n = 1160$ rpm

6. Technical Data

Technical data		Pump size																	
		B 6 B	B 7 B	B 8 B	B 10 B	B 10 D	B 12 B	B 12 D	B 14 B	B 14 D	B 16 B	B 16 D	B 18 B	B 18 D	B 20 B	B 22 B	B 24 B		
Rotation direction		Counterclockwise, seen from drive side																	
Minimum / maximum flow		0.4 x Qopt / 1.35 x Qopt																	
Maximum suction pressure (Kg/cm ²)		10																	
Maximum discharge pressure for Q=0 (Kg/cm ²)		20																	
Maximum temperature (°C)		80																	
Hydrostatic Test Pressure (Kg/cm ²)	Suction case	16																	
	intermediate bowl, discharge case, column pipe, discharge head	25																	
Column pipe diameter		4"	4"	6"	6"	6"	8"	8"	8"	10"	10"	10"	12"	12"	12"	14"	12"		
Column shaft diameter		1"	1 3/8"	1 3/8"	1 1/2"	1 1/2"	1 1/2"	1 1/2"	1 1/2"	2 3/8"	2 3/8"	2 3/8"	2 3/8"	2 3/8"	2 3/8"	2 3/4"	3 1/8"		
Intermediate column pipe length (mm)	Standard (mm)	2000	2500		2500						2500						2000		
	Optional (mm)	1500	2000 ⁷⁾		2000						1500								
top column pipe length(mm)		300 / 600 / 900				300 / 600 / 900 / 1200													
Drive with solid shaft	Discharge flange diameter	6"	6"	6"	6"	6"	8"	8"	10"	10"	10"	10"	12"	12"	12"	14"	12"		
	Discharge flange standard	ANSI B 16.5, 150 # R.F																	
	Thrust bearing ¹⁾	BUA 25			BUA35			BUA 45			BUA 60						BUA 75		
	Quantity and number of bearings (tanden disposition) ¹⁾	2 x BUA 7309 1 x 6010			2 x BUA 7312 1 x 6013			2 x BUA 7315 1 x 6016			2 x BUA 7318 1 x 6021						2xBUA7322 1 x 6226		
Drive with hollow shaft	Discharge flange diameter	4"	5"	6"	6"	6"	8"	8"	8"	10"	10"	10"	10"	10"	12"	14"	12"		
	Discharge flange standard	Standard: ANSI B 16.1, 125 # F.F - Optional: ANSI B 16.1, 250 # F.F																	
Column coupling		Threaded														Split			
Maximum stages number		25	21	18	15	15	12	12	10	10	8	8	7	7	6	5	5		
Maximum speed (rpm)		3600	3600	3600	3000	3000	1800	1800	1800	1800	1800	1800	1500	1500	1500	1500	1500		
Maximum ET (m) for discharge nozzle above the floor ^{3) 4)}		85	85	85	120	120	120	120	120	120	120	120	120	120	120	120	120		
Maximum ET (m) for discharge nozzle below the floor ⁴⁾		35	30	30	30	30	30	30	25	25	25	25	25	25	25	25	25		
Maximum P/n (HP/rpm) ²⁾	Pump shaft	0.013	0.027	0.05	0.068	0.068	0.184	0.184	0.24	0.24	0.45	0.45	0.67	0.67	0.83	1.16	1.16		
	Column shaft	0.027	0.049	0.049	0.12	0.12	0.12	0.12	0.12	0.46	0.46	0.46	0.46	0.46	0.46	0.92	0.92		
	Drive shaft	0.012	0.012	0.012	0.045	0.045	0.112	0.112	0.30	0.30	0.30	0.30	0.30	0.30	0.30	0.68	0.68		
Maximum thrust bearing (Kgf) accepted by the thrust bearing (downwards)	At the speed:	1200 rpm	1470 Kg			2180 Kg			3120 Kg			3880 Kg ⁵⁾						5600Kg ⁶⁾	
		1500 rpm	1360 Kg			2000 Kg			2880 Kg			3620 Kg ⁵⁾						5100Kg ⁶⁾	
		1800 rpm	1250 Kg			1880 Kg			2700 Kg			3400 Kg ⁵⁾						--	
		3000 rpm	1080 Kg			1600 Kg			--			--						--	
		3600 rpm	980 Kg			--			--			--						--	
Maximum solid contents		25 ppm – lubrication of pump bowl and columns bearings with pumped liquid - standard 100 ppm – lubrication of pump bowl and columns bearings by grease - standard – lubrication of pump bowl and columns bearings by oil - optional – lubrication of pump bowl and columns bearings by external source- optional																	

Notes:

- For applications where pump should start up against an opened discharge valve is required a special thrust bearing dimension.
- Valid for material SAE 1045. For other materials, please consider the following:

Material	Conversion Factor
ASTM A 276 T 410 (annealed).....	0.83
ASTM A 276 T 420 (annealed).....	0.97
ASTM A 276 T 316.....	0.55
ASTM A 276 T 431.....	1.66

Table 1

- In case of 3000 up to 3500 rpm speed, maximum ET is 50m.
- See ET on page 18. Maximum ET to column shaft and column pipe in steel. For other material, please consult Product Department.
- For higher axial thrust a segmental pad thrust bearing DS 60 can be used. It admits axial thrust down up to 5800 Kg with 1800 rpm speed.
- For higher axial thrust a segmental pad thrust bearing DS 80V can be used. It admits axial thrust down up to 8000 Kg with 1800 rpm speed.
- For 3000 up to 3600 rpm speed, the column pipe length should be 2000 mm.

7. Description

7.1 Pump Bowl

The case parts (suction case, intermediate bowl and discharge case) are vertically split respect to the shaft. The individual case parts are tightened together stud/nut arrangement and sealed by flat gaskets.

The suction case has a thread connection for optional suction strainer. Discharge case has flanged connections upon the column set assembly.

The impellers are single suction, mixed flow, enclosed and fixed by keys on the pump shaft. Pumps B18B, B20B, B22B and B24B have special 1° stage impeller.

The axial hydraulic thrust is taken up through a thrust bearing.

Suction case and intermediate bowl are provided with wear rings at the impeller suction side.

7.2 Discharge column

Discharge column is composed by intermediate and top column pipe including the following components:

- Column pipe with flanges at both ends manufactured according to KSB standard;
- 2 flat gaskets for flanges;
- column shaft, threaded on both ends;
- bearing spider;
- bearing bush;
- bearing sleeve (not applicable for execution with oil lubrication);
- shaft enclosing tube (applicable for execution with oil and clean water of external source lubrication)
- Threaded/split coupling.

Attention:

The column and top shafts are not protected against the medium. By the use of shaft enclosing tube only those shafts can be protected which lie above the maximum medium level. An adequate corrosion protection is possible only through selection of shaft and coupling material, which is resistant to medium.

8. Bearings and Lubrication

8.1 Thrust bearing

The thrust bearing has two angular contact ball bearings in tandem arrangement and one deep groove ball bearing (grease lubricated).

Thrust bearing shall be loaded through following components (directed towards suction side):

- hydraulic axial thrust of the pump. Figs. 5 and 6;
- weight of dynamic pump bowl parts. Consult Table 2;
- weight of column shafts and driver (top shaft). Consult Fig. 7;
- weight of ½ coupling (according to Manufacture's manual).

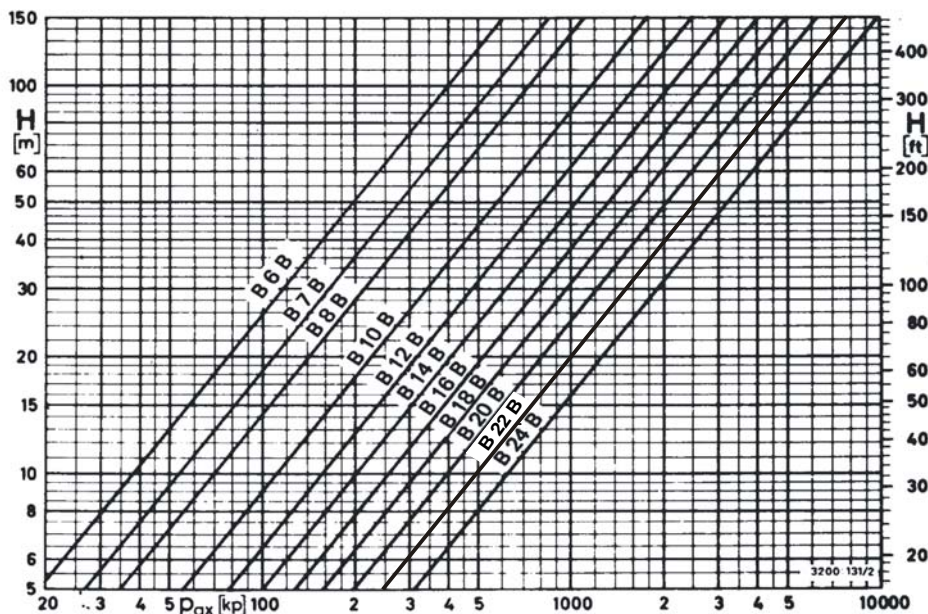

Fig 5 – Hydraulic axial thrust for Impeller type B.

H: Total head at operating point.

Pax: Axial thrust

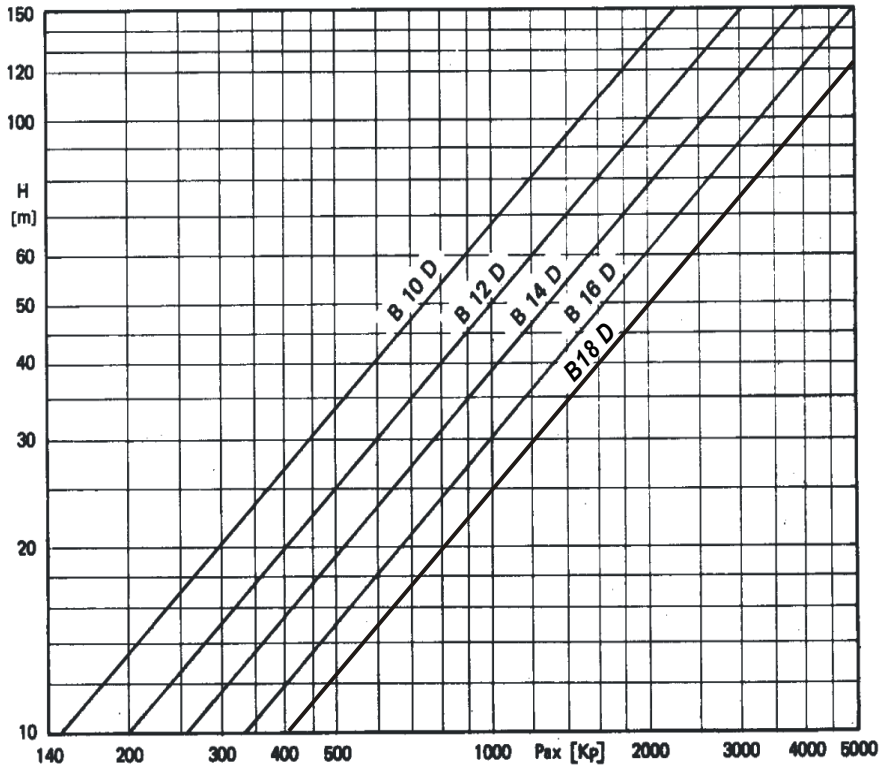
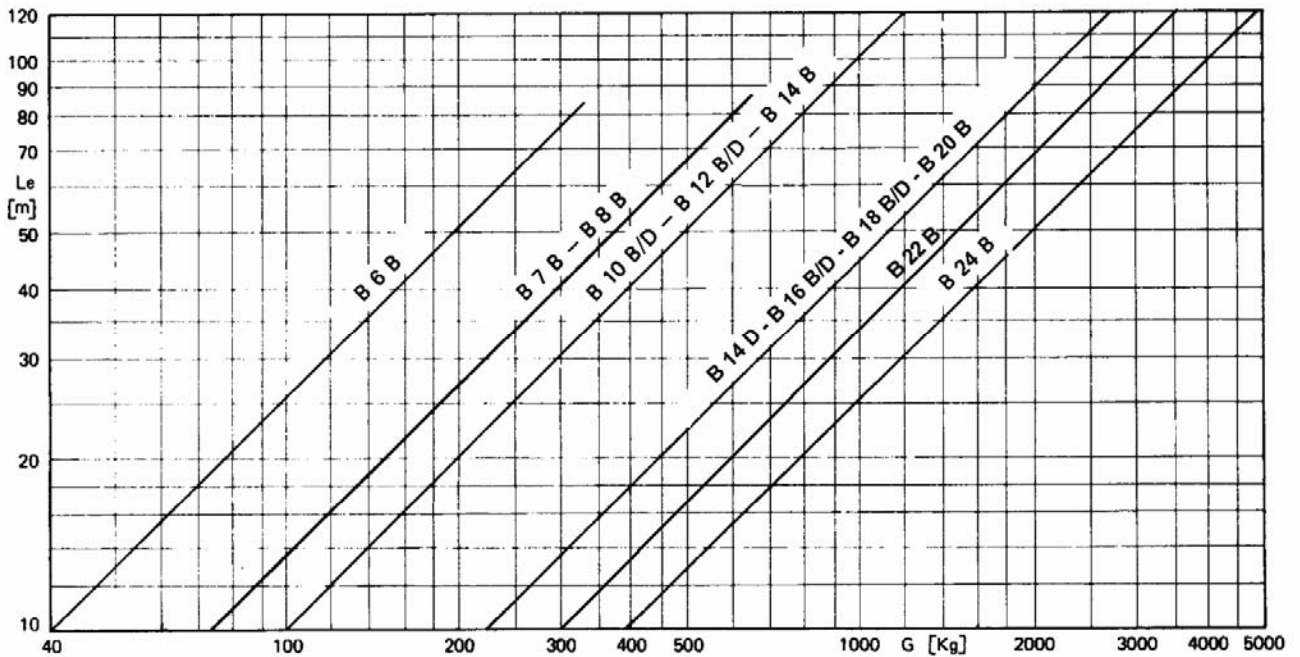

Fig 6 – Hydraulic thrust for Impeller type D.

Pump size	B 6	B 7	B 8	B 10	B 12	B 14	B 16	B 18	B 20	B 22	B 24
1° stage	2.4	3.8	5.8	10.3	17.2	29.1	54	38.5	67	80	94
Each additional stage	1.2	1.8	2.8	4.9	8.4	15.1	30.5	21.7	41	52	63

Table 2 – Weight of dynamic pump bowl parts (kg).



Le = Total column and drive (top) shafts length.

Fig 7 – Weight of column and drive shafts including shaft protecting sleeve and column couplings.

Notes:

- a) For application with pressures in the suction side (under pressure tank, booster, etc), please consult KSB.
- b) In hollow shaft drivers (electric motor or angle gear) the axial thrust is supported by the thrust bearing located in the driver.
The axial thrust should be calculated as above specification and should be informed to the driver manufacturer during consult and purchase.
Instead of ½ coupling weight should be considered the weight of drive/top shaft.
- c) The thrust bearing up to size BUA75 is cooled by ambient air convection.
The DS60 and DS80V thrust bearing have a water cooling chamber(0.3 up to 0.4 m³/h) of external source or from the pumped liquid, if it complies with the following criteria:
 - max. inlet temperature: 30°C
 - max. inlet pressure: 5 kg / cm²
 - min. inlet pressure: 1 kg / cm²
 - non corrosive
 - clean water

For cooling water flow control is supplied a gate valve in the cooling inlet chamber.

8.2 Pump bearing

The suction case bearing is made of bronze and grease lubricated with permanent charge. Intermediate bowl bearings are vulcanized and lubricated by pumped liquid.

8.3 Discharge column bearing

The discharge column bearing is determined considering the type of lubrication and the following factors:

- solid contents;
- contaminate pumped liquid with small quantities of oil or grease allowable;
- external source liquid availability;
- pre-lubrication in column bearing above the minimum level of suction well.

	Lubrication type	Column shaft execution	Column bearing type	With or without shaft protective sleeve	Notes
STANDARD EXECUTION	Pumped liquid	Without shaft enclosing tube	Steel / Rubber or elastomer	With protective sleeve	Column bearings should be pre-lubricated when the pump has two or more column bearings above the minimum level of suction well.
	Grease		Bronze		
OPTIONAL	Oil	With shaft enclosing tube ¹⁾	Bronze	Without protective sleeve	---
	Clean water of external source		Steel / Rubber or elastomer	With protective sleeve	Maximum solid contents for Clean water of external source = 20 ppm.

Table 3 ¹⁾ For size B22B and B24B is available only the execution without shaft enclosing tube and split coupling.

9. Lubrication

9.1 Pumped liquid lubrication

If pre-lubrication is necessary, it can be done in a tank of approximately 50 liters installed above the top column bearing. The gate valve must be connected between the tank and the column pipes. Before start-up, the gate valve must be opened for pre-lubrication of column bearings. Tank and piping with gate valve can be optionally supplied.

9.2 Grease lubrication

A grease pump with electrical motor will be fixed in the drive stool or discharge head. The grease pump has approximately 5 liters in a reservoir and an alarm contact to indicate low quantity of grease. Each column bearing receives a charge of grease separately. The command panel of grease pump electrical motor (normally not supplied by KSB) should be interconnected with main motor panel. If the pump remains in stand by for some days, the grease pump should start up before the electrical motor to guarantee the bearing pre-lubrication.

The size of grease pump, motor power, voltage and supplier is defined by the number of column bearings and grease quantity per bearing.

Pump Size	B 6 B	B 7 B / B 8 B	B 10 B / B 10 D B 12 B / B 12 D B 14 B	B 14 D / B 16 B B 16 D / B 18 B B 18 D / B 20 B	B 22 B / B 24 B
Grease quantity per column bearing g/h	2.0	2.5	2.8	5.6	9.4

Table 4

9.3 Oil lubrication

On the drive stool or discharge head is installed a reservoir with approximately 4 liters. Splash lubrication allows the oil quantity adjustment. Between the splash piping and the shaft enclosing tube is connected a solenoid valve that closes the oil charging during the stand by. Connection between solenoid and motor panel should be considered. Voltage of solenoid valve should be defined.

Note: Inside pressure in the shaft enclosing tube is not allowable. Therefore the discharge case has a threaded bush with a compensation bore interconnected to the well.

9.4 Clean water of external source lubrication

On the drive stool or discharge head is assembled the feeding piping of external source clean water to the shaft enclosing tube. The gate valve, flow control valve and pressure gauge are included in our supply. Before the motor starting be sure that column bearings received external source clean water.

10. Shaft sealing

Stuffing box packing is used to seal the shaft at the motor stool or discharge head. The stuffing box packing have 3 up to 5 packing rings assembled in series (depends on the pump size and the lubrication type). The shaft is protected in the sealing area by a shaft protecting sleeve. The oil lubricated or external source clean water have in the top of shaft enclosing pipe an o'ring that avoid oil or external source water leakage.

11. Drive, coupling and drive stool

The following drive methods can be used:

STANDARD	Drive type	See fig.	Coupling type	Pump axial thrust	Drive stool
		Vertical electrical motor with flange "solid shaft"	8	Elastic	Thrust bearing assembled in the drive stool
OPTIONAL	Vertical electrical motor with flange "hollow shaft" (special manufacture)	9	rigid	Thrust bearing assembled on the top motor. The motor also has a non reversion ratchet	Cast iron
	By diesel motor through vertical angle gear with "hollow shaft" flange (special manufacture)	10	Rigid The diesel motor coupling with angle gear should be done with cardan shaft, minimum length of 1.0 m	Thrust bearing on the top part of angle gear. The angle gear has a non reversion ratchet	Cast iron

Table 5

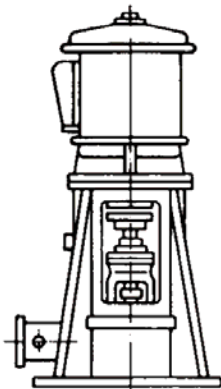

Fig. 8

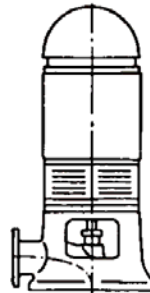

Fig. 9

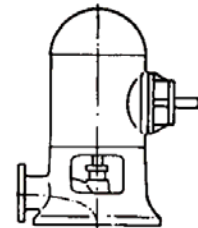

Fig. 10

Note: For execution with discharge nozzle below the floor, please consult KSB.

11.1 Drive stool VN type or VU type (optional)

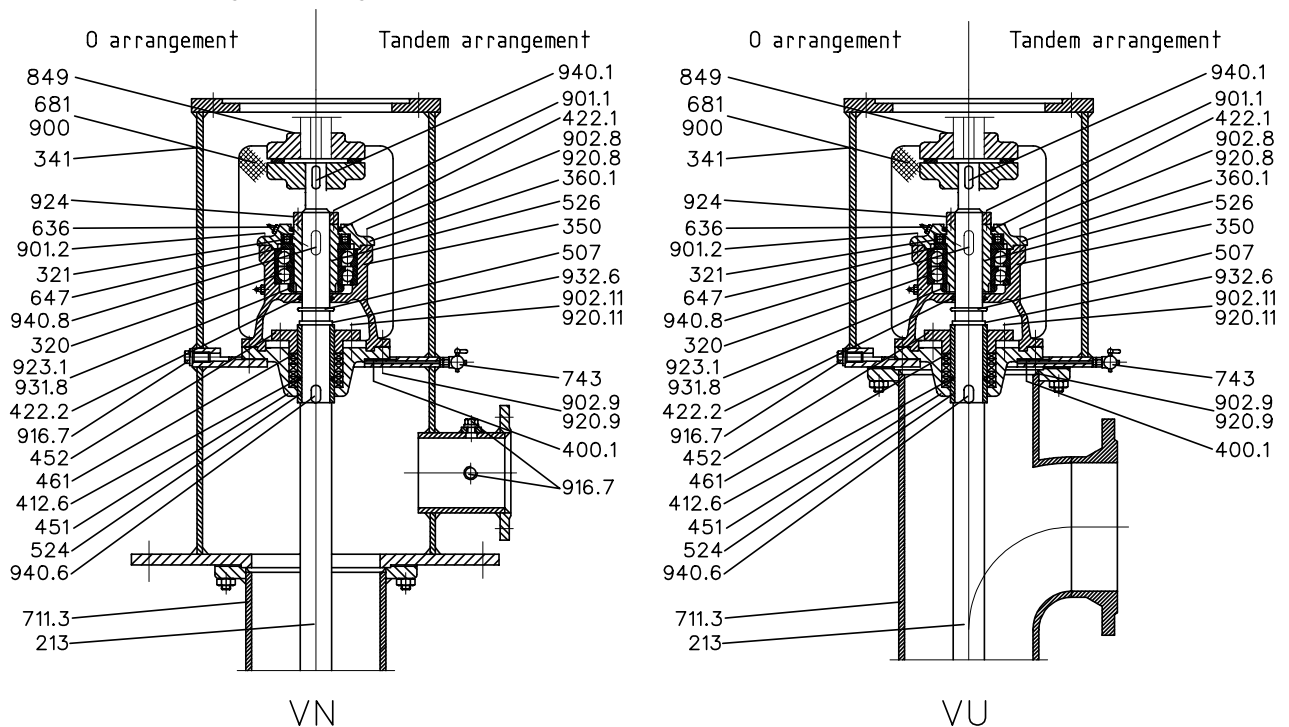

Fig. 11 – Standard Drive stool for V1 motors

Item No.	Designation	Item No.	Designation	Item No.	Designation
213	Drive/top shaft	451	Stuffing box housing	900	Screw
320	Angular contact ball bearing	452	Stuffing box gland	901.1/.2	Screw
321	Deep groove ball bearing	461	Stuffing box packing	916.7	Plug
341	Drive stool / discharge head	507	Thrower	920.8/.9/.11	Lock nut
350	Bearing housing	526	Centering sleeve	923.1	Bearing nut
360.1	Bearing cover	636	Grease nipple	924	Adjusting nut
400.1	Flat gasket	647	Grease feed regulator	931	Lock washer
412.6	O-ring	681	Coupling guard	932.6	Circlip
422.1/.2	Felt ring	711.3	Column pipe		

11.2 Starting Torque

The initial breakaway torque amounts to approximately 15 % from rated moment. In Figure 12 the approximate running at start is shown.

- I. With open gate valve
- II. Against closed gate valve – Impeller type “B”
- III. Against closed gate valve – Impeller type “D”

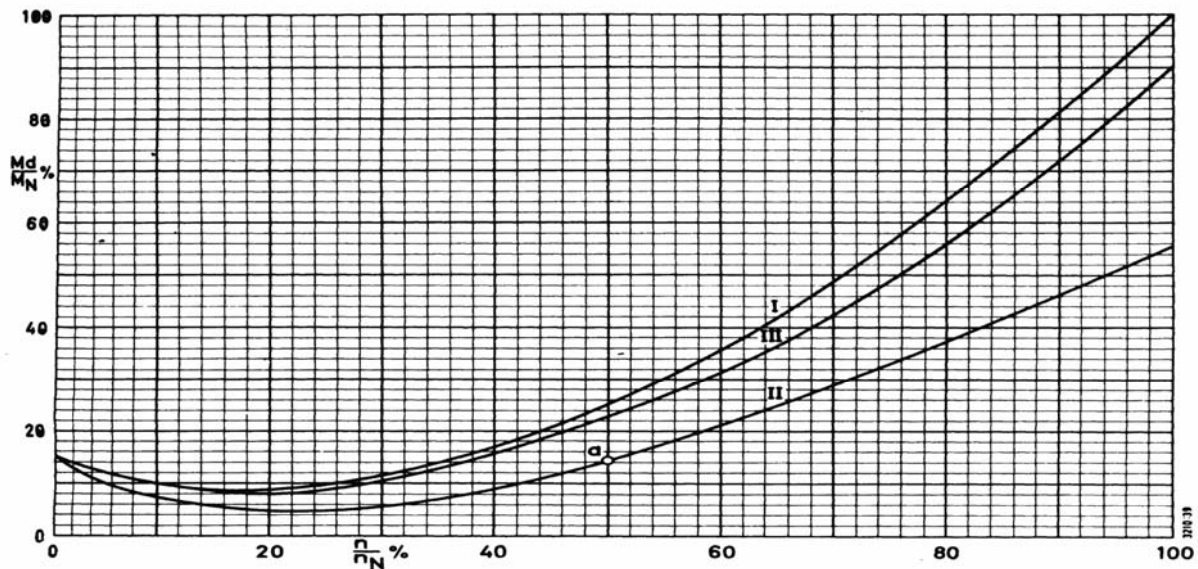

Fig. 12 – Starting Torque Curve

11.2.1 Torque M_d

The torque can be calculated with this formula

$$M_d = 9549 \times P/n, \text{ where}$$

P = Power requirement at the shaft (motor rating) in kW

n = Revolutions of the pump rpm

9549 = Constant

12. Pump weight

The total pump weight is the sum of the following components:

- pump bowl;
- column pipe (including bearing spider, column shaft, column coupling, bearing bush, screws and nuts);
- shaft protecting sleeve, if applicable;
- Discharge head with or without thrust bearing according the drive type.

Pump size		B 6 B	B 7 B	B 8 B	B 10 B/D	B 12 B/D	B 14 B/D	B 16 B/D	B 18 B/D	B 20 B	B 22 B	B 24 B	
Pump bowl weight (kg)	Stages number	1	22	32	44	72	112	160	220	295	385	530	640
		2	28	41	56	96	154	222	305	407	545	785	940
		3	34	50	68	120	196	284	390	519	705	1040	1240
		4	40	59	80	144	238	346	475	631	865	1295	1540
		5	46	68	92	168	280	408	560	743	1025	1550	1840
		6	52	77	104	192	322	470	645	855	1185		
		7	58	86	116	216	364	532	730	967			
		8	64	95	128	240	406	594	815				
		9	70	104	140	264	448	656					
		10	76	113	152	288	490	718					
Weight of intermediate column pipe set (Kg)	length	1500 mm	31	-	-	-	-	138	169	-	-	-	
		2000 mm	36	51	71	77	118	-	-	255	255	-	
		2500 mm	-	60	84	90	140	201	248	-	-	-	
Weight of top column pipe (Kg)	length	300 mm	7	8	11	12	18	25	31	-	-	34	
		600 mm	14	15	22	24	35	49	62	-	-	67	
		900 mm	21	23	33	36	53	74	93	-	-	101	
		1200 mm	27	30	44	47	69	98	124	-	-	133	
Weight of shaft enclosing tube per meter (Kg/m)		3.3	5.1		6.4		16				-		
Driver with solid shaft	Weight of discharge head with thrust bearing	215			220	320	700			1100			
Driver with hollow shaft	Weight of discharge head without thrust bearing	150	245	237		345	535			785			

Table 6

13. Load for foundation

Load for foundation is the sum of :

- pump weight
- coupling weight
- driver weight
- accessories weight
- pump liquid weight, which will be calculated as following:
weight = volume (dm³) x density (kg / dm³).

Volume = ET (see page 18) + 1m (Discharge head approx. height) multiply by the values on table 7.

Pump size	B 6 B B 7 B	B 8 B B 10 B B 10 D	B 12 B B 12 D B 14 B	B 14 D B 16 B B 16 D	B 18 B B 18 D B 20 B B 22 B B 24 B
Volume (dm ³)	7.8	17.6	32.5	50.9	72.2

Table 7

Notes:

The axial hydraulic thrust is an internal force of motor-pump set.
The axial hydraulic thrust is not transmitted to the foundations.

14. Assembly height

The minimum height of crane hook to assemble and disassemble the pump should be 1.5 time of column pipe or pump bowl height prevailing higher value.

15. Inertia Moment (GD²)

GD² Total = GD² (pump bowl with water) + n x GD² (column shaft) + GD² (drive/top shaft) + GD² (drive coupling ^(*))

n = column shafts quantity

^(*) according to the manufacturer

		B 6 B	B 7 B	B 8 B	B 10 B	B 10 D	B 12 B	B 12 D	B 14 B	B 14 D	B 16 B	B 16 D	B 18 B	B 20 B	B 22 B	B 24 B	
Pump bowl with water	Stages number	1	0.006	0.012	0.025	0.072	0.073	0.17	0.18	0.34	0.37	0.65	0.68	1.2	1.8	2.9	4.8
		2	0.011	0.023	0.045	0.134	0.136	0.32	0.34	0.64	0.69	1.20	1.26	2.2	3.4	5.5	9.3
		3	0.016	0.034	0.065	0.196	0.199	0.47	0.50	0.94	1.01	1.75	1.84	3.2	5.0	8.1	13.8
		4	0.021	0.045	0.085	0.258	0.262	0.62	0.66	1.24	1.33	2.30	2.42	4.2	6.6	10.7	18.3
		5	0.026	0.056	0.105	0.320	0.325	0.77	0.82	1.54	1.65	2.85	3.00	5.2	8.2	13.3	22.8
		6	0.031	0.067	0.125	0.382	0.388	0.92	0.98	1.84	1.97	3.40	3.58	6.2	9.8		
		7	0.036	0.078	0.145	0.444	0.451	1.07	1.14	2.14	2.29	3.95	4.16	7.2			
		8	0.041	0.089	0.165	0.506	0.514	1.22	1.30	2.44	2.61	4.50	4.74				
		9	0.46	0.100	0.185	0.568	0.577	1.37	1.46	2.74	2.93						
		10	0.051	0.111	0.205	0.630	0.640	1.52	1.62	3.04	3.25						
column shaft	length	1500 mm	0.0031	-	-				0.085				-				
		2000 mm	0.0036	0.0125	0.0193				-				0.334				
		2500 mm	-	0.0145	0.0233				0.125				-				
Drive/top shaft		0.0038			0.0109			0.030			0.102				0.319		

Tables 8 – GD² in Kgm² of pump bowl, column shaft and drive / top shaft. B 18 D under consults.

Pump power consumption	Power reserve for drive motor
Up to 30 CV	Approximately 20 %
Up to 100 CV	Approximately 15 %
Above 100 CV	Approximately 10 %

Table 9 – Driver power reserve

16. Installation

Installation must be always done at the vertical position in wells, reservoirs, rivers, etc. The pumping unit has been designed to suit outdoor installation. The thrust bearings are sealed against the penetration of dust, sand, spray water, etc. The pump stands completely or partially installed in the pumping medium up to the level of 1st stage impeller. The minimum submergence of the impeller of 1st stage should correspond to the measurement "B" (minimum submergence). In case there is a suction pipe attached with suction strainer then the water level can fall below the level of 1st stage impeller. In this case care should be taken that the cavitation does not take place. For this the minimum medium level should be once time of DN over the upper edge of the suction strainer.

The minimum submergence is defined by:

- Pump required NPSH. The installation available NPSH should be superior to pump required NPSH.
- Avoid vortex and air suction to guarantee first stage impeller submergence to assure functioning in the pump start-up.

17. Minimum submergence

The minimum submergence to guarantee the installation criteria is indicated in the figures below.

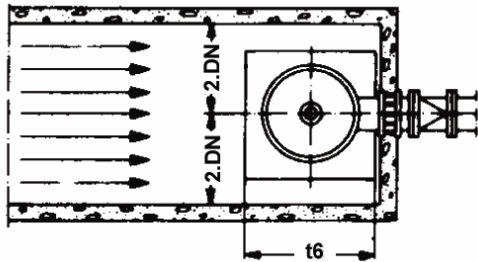

Fig. 13

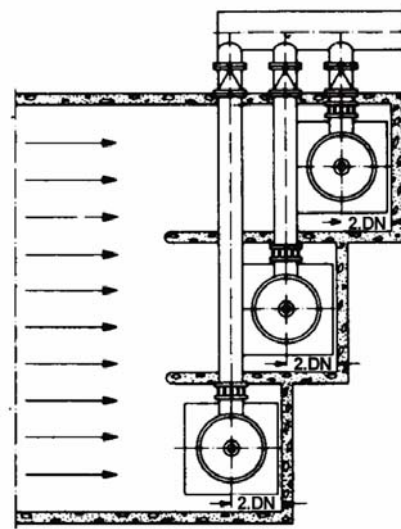

Fig. 16

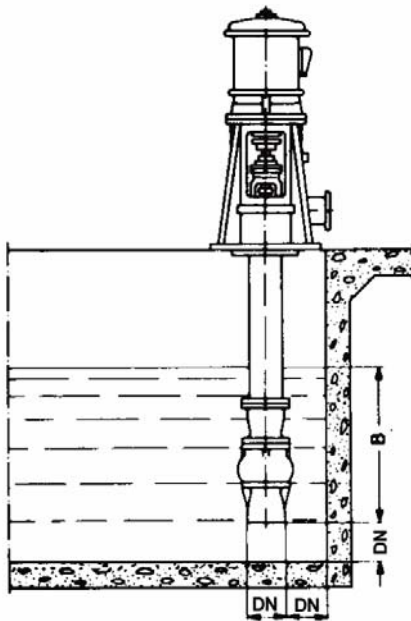

Fig. 14

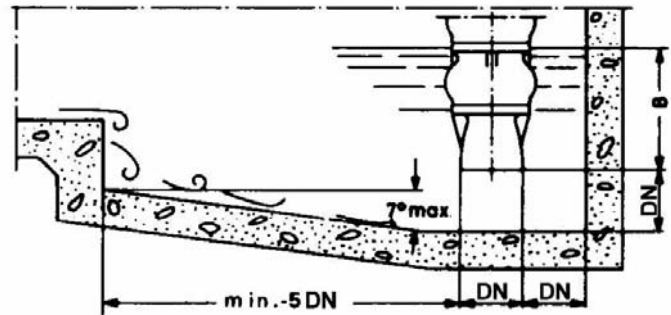

Fig. 17

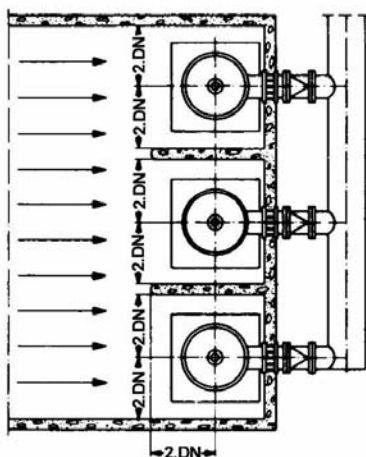

Fig. 15

Note: DN and t6 see topic 20.

Pump size	B 6	B 7	B 8	B 10	B 12	B 14	B 16	B 18	B 20	B 22	B 24
B (mm)	300	300	350	400	450	450	450	500	500	500	500

Table 10

18. Discharge head and column pipe friction losses and flow resistance in suction strainer

18.1 Discharge head friction losses. Material: Carbon steel.

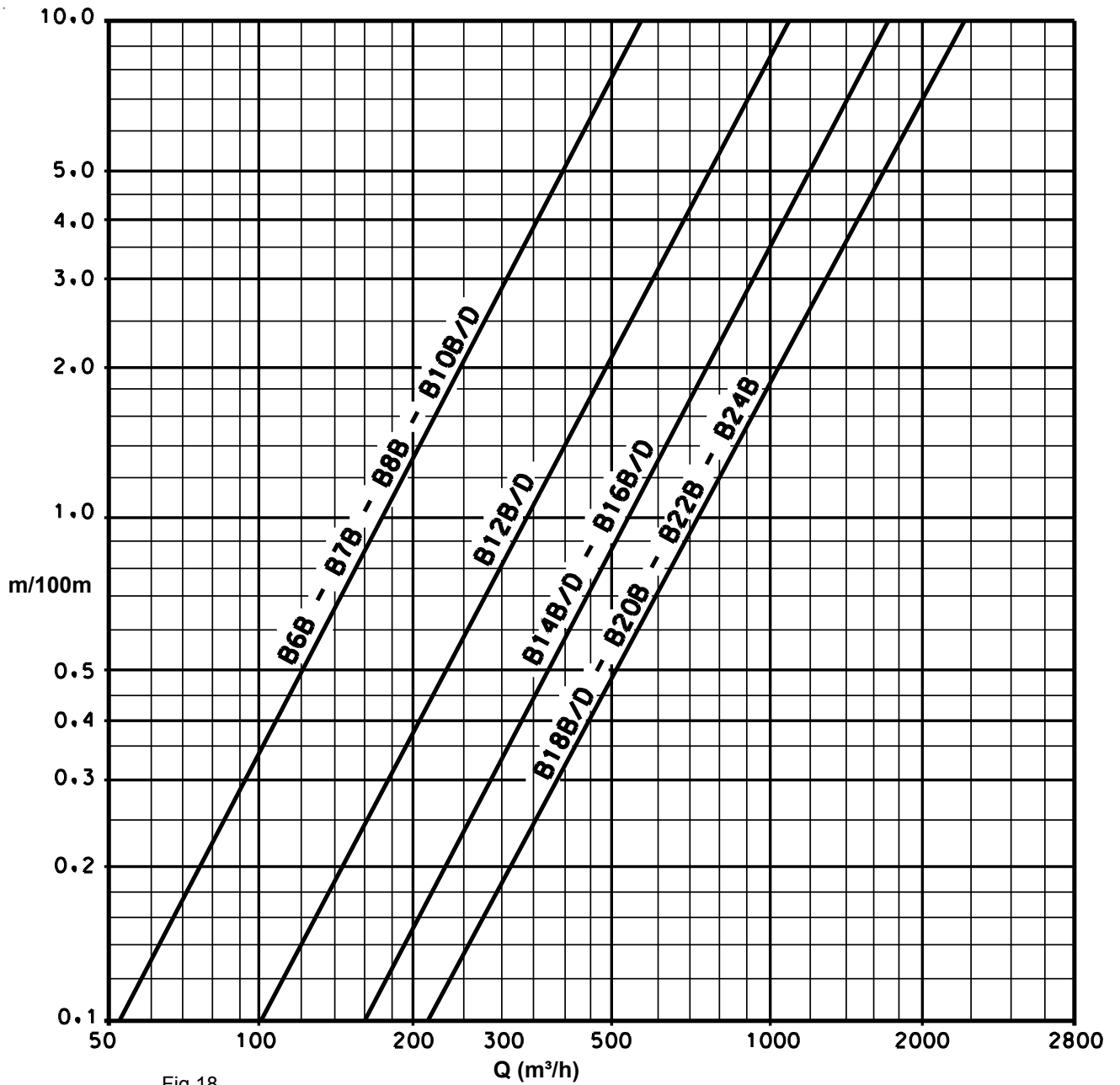

Fig.18

Note:

- Table values are to be multiplied by 0.3, for cast iron.

18.2 Column pipe friction losses without shaft enclosing tube, for set length of 2500 mm

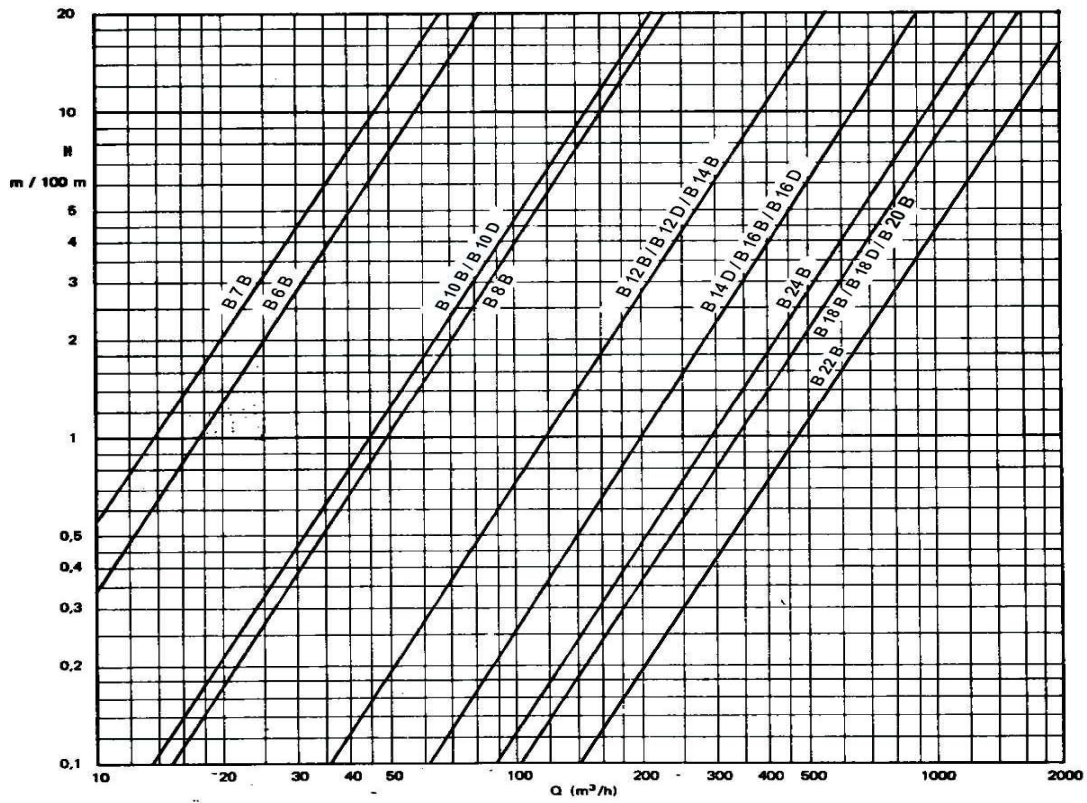

fig.19

Notes:

- Table values are to be multiplied by 1.1, for set length of 2000 mm.
- Table values are to be multiplied by 1.2, for set length of 1500 mm.

18.3 Column pipe friction losses with shaft enclosing tube, for set length of 2500 mm

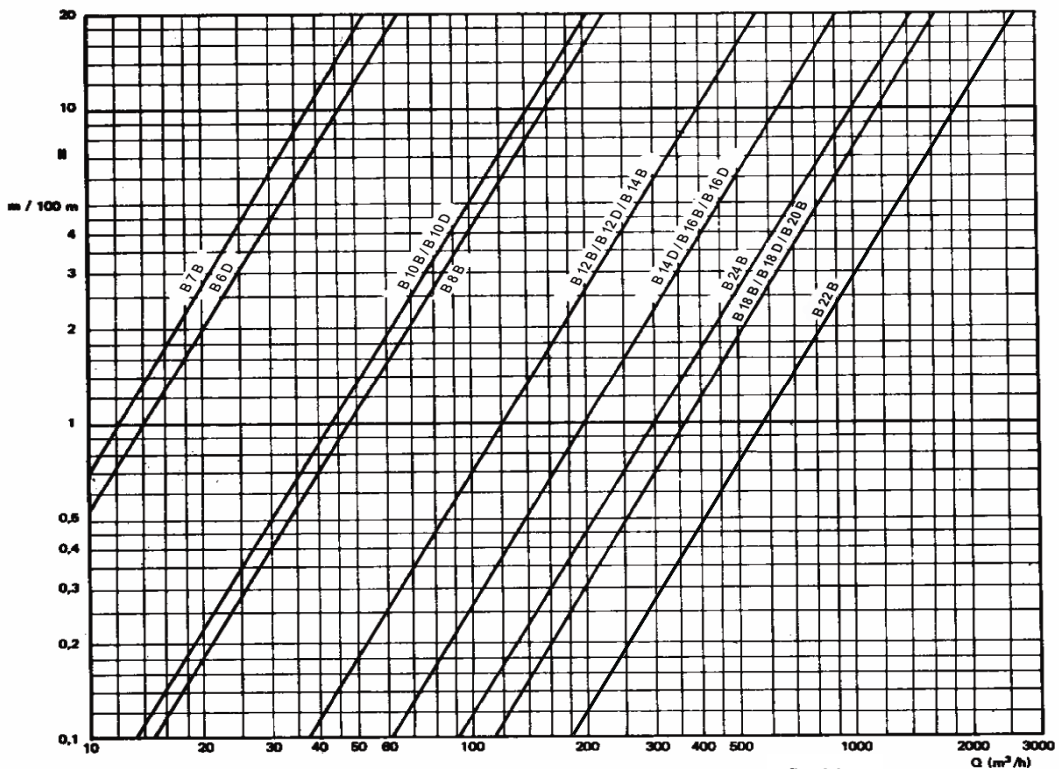

fig.20

Note:

- Table values are to be multiplied by 1.1, for set length of 1500 mm.

18.4 Flow resistance in suction strainer

Suction strainer is not part of supply, but can be optionally requested.

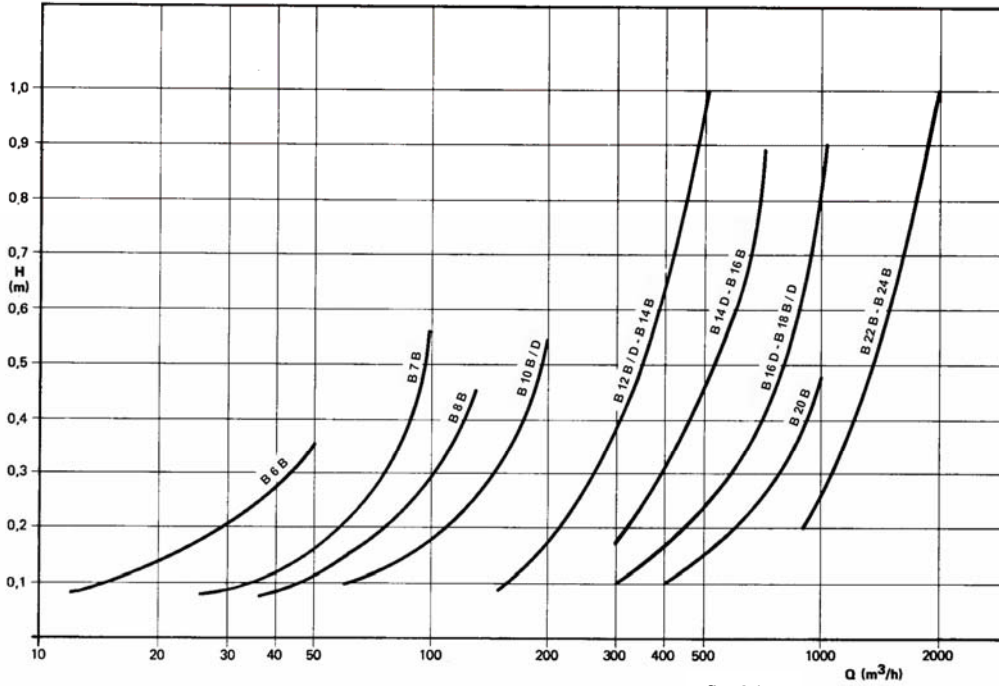

fig.21

19. Bearing and stuffing box friction losses

19.1 Bearing friction losses for set length of 2500 mm

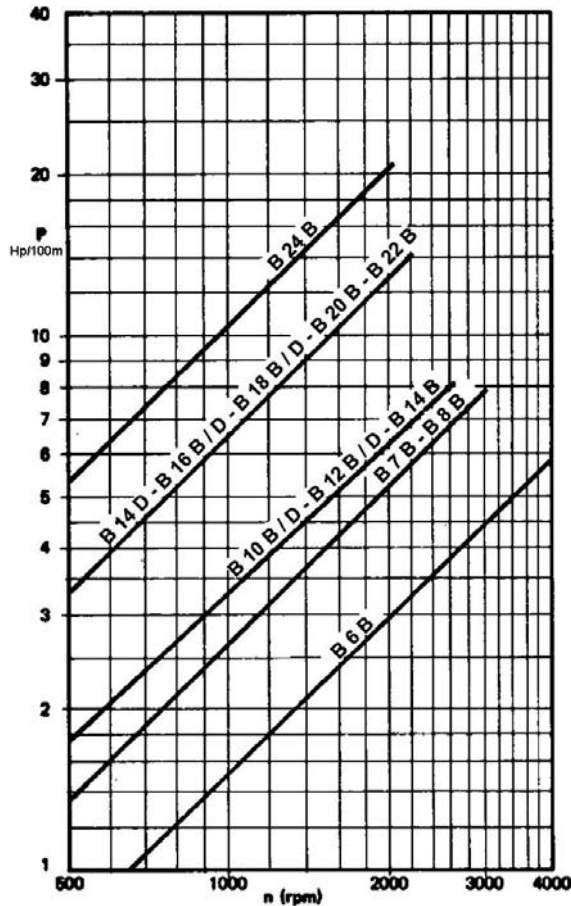
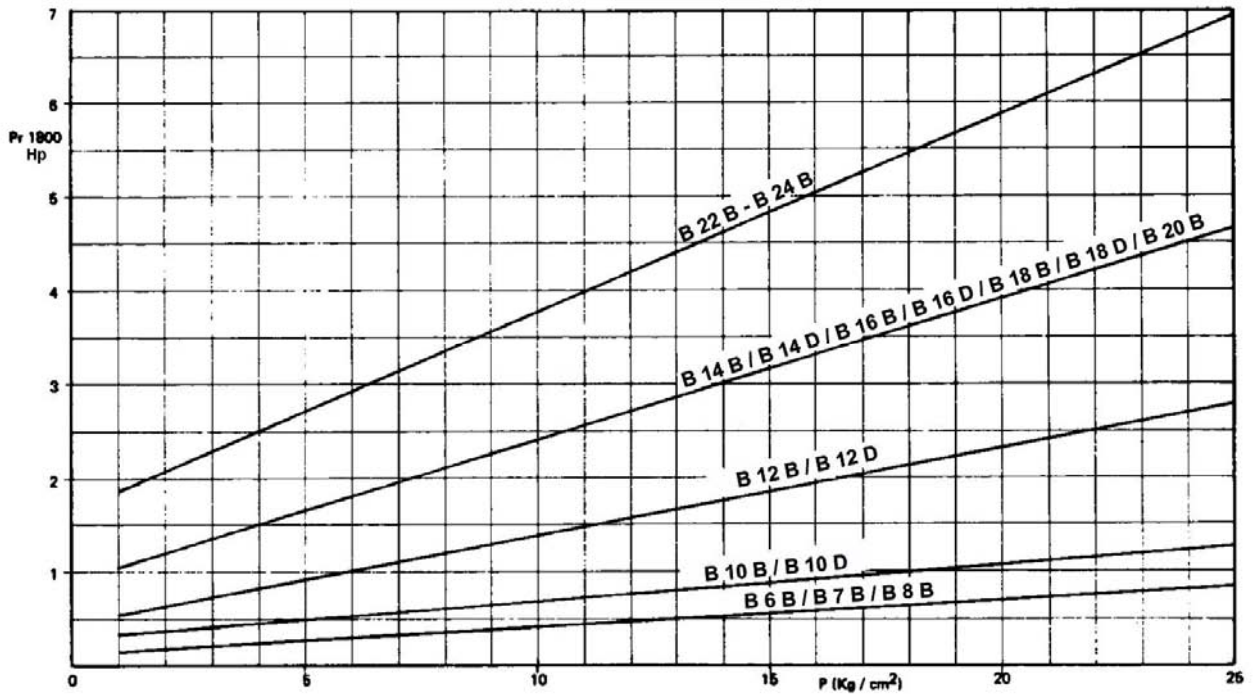

fig.22

Note:

- Table values are to be multiplied by 1.25, for set length of 2000 mm.
- Table values are to be multiplied by 1.65, for set length of 1500 mm.

19.2 Stuffing box friction losses - 1800 rpm



Note: For different speeds use the following formula:

$$Pr = \frac{\text{Nominal Speed} \times Pr\ 1800}{1800}$$

20. Dimension tables (in mm)

Pump Size	t ₂ Intern. column pipe length •STD. □OPT.	t ₃ top column pipe length	t ₈ (opt.)	DN	d ₁	d ₂ (pol)	d ₃	d ₄	d ₅	t ₁	STAGES																																	
											1	2	3	4	5	6	7	8	9	10	11	12	13	14	15	16	17	18	19	20	21	22	23	24	25									
											B 6 B	•2000 □1500	300 600 900	135	80	140	4"	198	250	200	455	555	655	755	855	955	1055	1155	1255	1355	1455	1555	1655	1755	1855	1955	2055	2155	2255	2355	2455	2555	2655	2755
B 7 B	220	505	625	745	865	985	1105	1225	1345	1465	1585	1705									1825	1945	2065	2185	2305	2425	2545	2665	2785	2905														
B 8 B	•2500 □2000	300 600 900 1200	240	125	190	6"	258	300	250	545	685	825	965	1105	1245	1385	1525	1665	1805	1945	2085	2225	2365	2505	2645	2785	2925																	
B 10 B										285	615	780	945	1110	1275	1440	1605	1770	1935	2100	2265	2430	2595	2760	2925																			
B 12 B										720	920	1120	1320	1520	1720	1920	2120	2320	2520	2720	2920																							
B 12 D	350	200	290	8"	330	350	340	340	340	765	1000	1235	1470	1705	1940	2175	2410	2645	2880																									
B 14 B	•2500 □1500	300 600 900 1200	415	250	382	10"	370	400	395	830	1100	1370	1640	1910	2180	2450	2720																											
B 14 D										445	890	1190	1490	1790	2090	2390	2690																											
B 16 B										505	955	1290	1625	1960	2295	2630																												
B 16 D	500	350	472							1050	1450	1850	2250	2650																														
B 18 B	•2500 □1500	300 600 900 1200	580	400	560	14"	470	500	565	1060	1470	1880	2290																															
B 18 D										1060	1470	1880	2290																															
B 20 B	•2000	300 600 900 1200	580	400	560	14"	470	500	565	1060	1470	1880	2290																															
B 22 B										1060	1470	1880	2290																															
B 24 B	•2000	300 600 900 1200	580	400	560	14"	470	500	565	1060	1470	1880	2290																															

Table 11

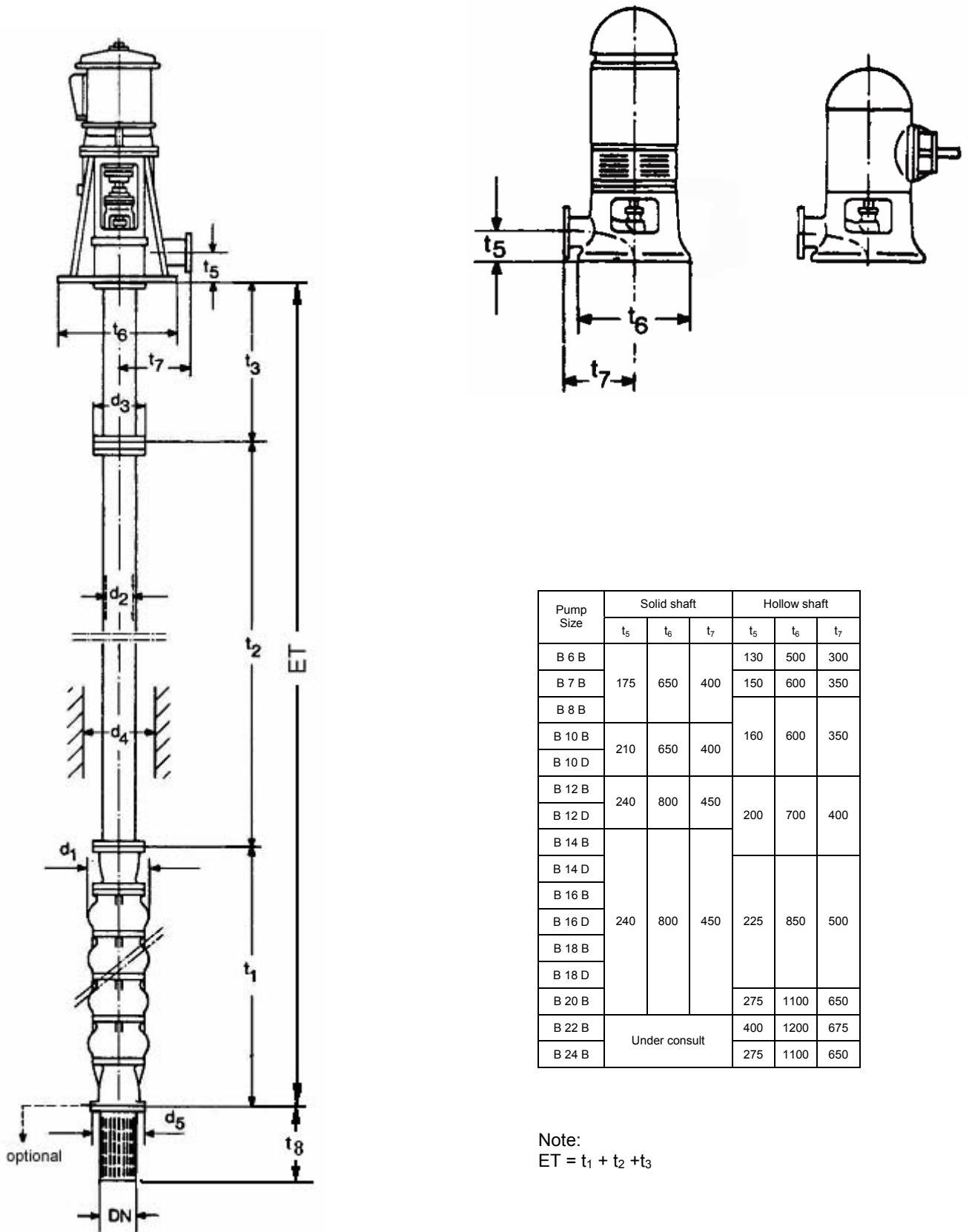

Pump Size	Solid shaft			Hollow shaft		
	t_5	t_6	t_7	t_5	t_6	t_7
B 6 B				130	500	300
B 7 B	175	650	400	150	600	350
B 8 B						
B 10 B	210	650	400	160	600	350
B 10 D						
B 12 B	240	800	450	200	700	400
B 12 D						
B 14 B	240	800	450			
B 14 D						
B 16 B						
B 16 D	240	800	450	225	850	500
B 18 B						
B 18 D						
B 20 B				275	1100	650
B 22 B	Under consult			400	1200	675
B 24 B	Under consult			275	1100	650

Note:
 $ET = t_1 + t_2 + t_3$

Table 12

21. Sectional drawings, parts and material list

21.1 Pumped liquid lubricated

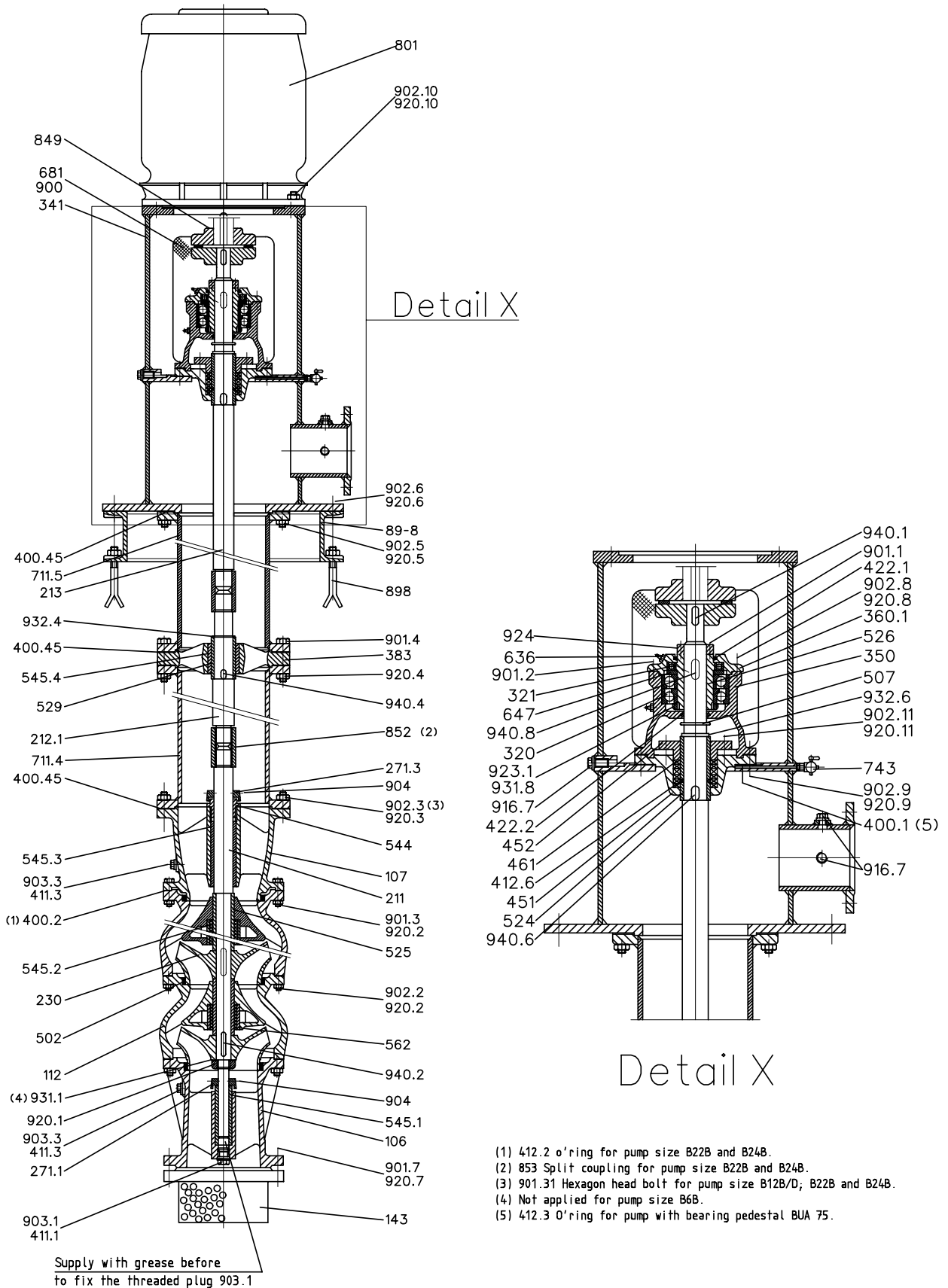

Part no.	Denomination	Standard material ①
106	Suction case	A48CL30
107	Discharge case	A48CL30
112	Intermediate bowl	A48CL30
143	Strainer (optional)	SAE 1020
211	Pump shaft	SAE 1045
212	Column shaft	SAE 1045
213	Drive shaft	SAE 1045
230	Impeller	A48CL30
271	Sand guard	TM 23
320	Angular contact ball bearing	(see table 1)
321	Deep groove ball bearing	(see table 1)
341	Drive stool	SAE 1020
350	Bearing housing	A48CL30
360	Bearing cover	A48CL30
383	Bearing spider	A48CL30
400	Flat gasket	Hydraulic gasket
411	Sealing ring	Copper
412	"O" ring	NB 70
422	Felt ring	Felt
451	Stuffing box housing	A48CL30
452	Stuffing box gland	A48CL30
461	Stuffing box packing	Aramid & graphite
502	Casing wear ring	A48CL30
507	Deflector	Buna N *
524	Shaft protecting sleeve	AISI 316
525	Spacer sleeve	TM 23
526	Centering sleeve	SAE 1045
529	Bearing sleeve	AISI 316
544	Threaded bush	TM 23
545	Bearing bush	Steel/NB 70
562	Cylindrical pin	SAE 1020
636	Grease nipple	Galvanized steel
647	Grease regulator	SAE 1020
681	Coupling guard	SAE 1020
711	Column pipe	(see note 2)
743	Suction strainer	Brass
801	Flange motor	---
849	Coupling	---
852	Threaded coupling	AISI 420
89-8	Foundation rail	SAE 1020
898	Anchor bolt	SAE 1020
900	Bolt	SAE 1020
901	Hexagon head bolt	SAE 1020
902	Stud	SAE 1020
903	Threaded plug	SAE 1020
904	Threaded pin	Steel
916	Threaded plug	SAE 1020
920	Nut	SAE 1020
923	Bearing nut	Aço
924	Adjusting nut	SAE 1045
931	Lockwasher	SAE 1045
932	Circlip	Spring steel
940	Key	SAE 1045

Note:

①-Other materials under consult

②-SCH 40 ASTM A106GR.A (seamless):

For B 18, B 20 and B 24 – SAE 1020 (with seam)

* AISI 316 for BUA 75

21.2 Grease lubricated

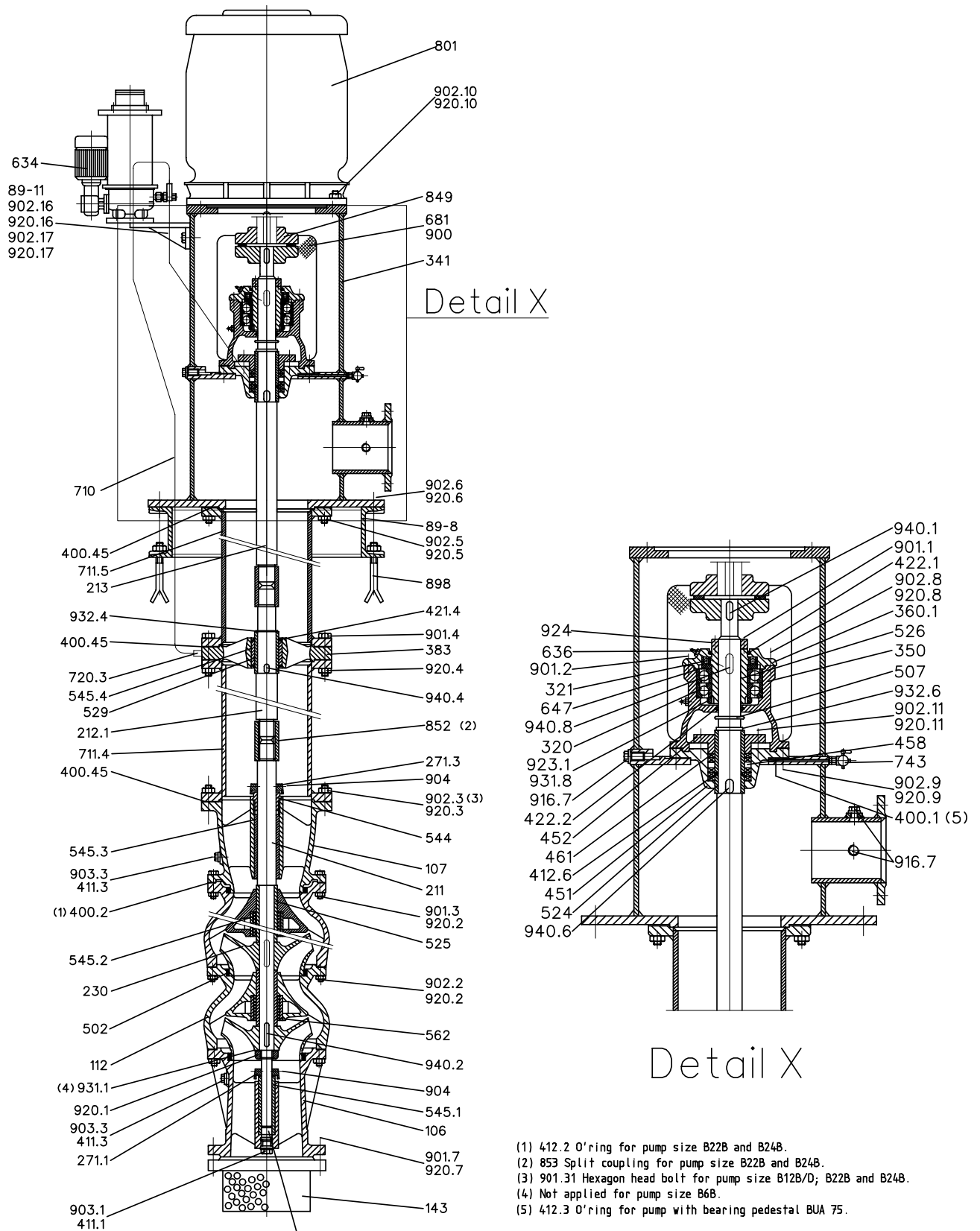

Fig. 28

- (1) 412.2 O'ring for pump size B22B and B24B.
- (2) 853 Split coupling for pump size B22B and B24B.
- (3) 901.31 Hexagon head bolt for pump size B12B/D; B22B and B24B.
- (4) Not applied for pump size B6B.
- (5) 412.3 O'ring for pump with bearing pedestal BUA 75.

Part no.	Denomination	Standard material ①
106	Suction case	A48CL30
107	Discharge case	A48CL30
112	Intermediate bowl	A48CL30
143	Strainer (optional)	SAE 1020
211	Pump shaft	SAE 1045
212	Column shaft	SAE 1045
213	Drive shaft	SAE 1045
230	Impeller	A48CL30
271	Sand guard	TM 23
320	Angular contact ball bearing	(see table 1)
321	Deep groove ball bearing	(see table 1)
341	Drive stool	SAE 1020
350	Bearing housing	A48CL30
360	Bearing cover	A48CL30
383	Bearing spider	A48CL30
400	Flat gasket	Hydraulic gasket
411	Sealing ring	Copper
412	"O" ring	NB 70
421	Radial seal ring	Steel / Rubber
422	Felt ring	Felt
451	Stuffing box housing	A48CL30
452	Stuffing box gland	A48CL30
458	Lantern ring	A48CL30
461	Stuffing box packing	Aramid & graphite
502	Casing wear ring	A48CL30
507	Deflector	Buna N *
524	Shaft protecting sleeve	AISI 316
525	Spacer sleeve	TM 23
526	Centering sleeve	SAE 1045
529	Bearing sleeve	AISI 420
544	Threaded bush	TM 23
545	Bearing bush	TM 23
562	Cylindrical pin	SAE 1020
634	Grease pump	---
636	Grease nipple	Galvanized steel
647	Grease regulator	SAE 1020
681	Coupling guard	SAE 1020
710	Lubricating pipe	Steel
711	Column pipe	(see note 2)
720	Conection	Steel
743	Suction strainer	Brass
801	Flange motor	---
849	Coupling	---
852	Threaded coupling	AISI 420
89-8	Foundation rail	SAE 1020
89-11	Angular support	SAE 1020
898	Anchor bolt	SAE 1020
900	Bolt	SAE 1020
901	Hexagon head bolt	SAE 1020
902	Stud	SAE 1020
903	Threaded plug	SAE 1020
904	Threaded pin	Steel
916	Threaded plug	SAE 1020
920	Nut	SAE 1020
923	Bearing nut	Aço
924	Adjusting nut	SAE 1045
931	Lockwasher	SAE 1045
932	Circlip	Spring steel
940	Key	SAE 1045

Notes:

①-Other materials under consult

②-SCH 40 ASTM A106GR.A (seamless):

For B 18, B 20 and B 24 – SAE 1020 (with seam)

* ANSI 316 for BUA 75

21.3 Oil lubricated (shaft enclosing tube)

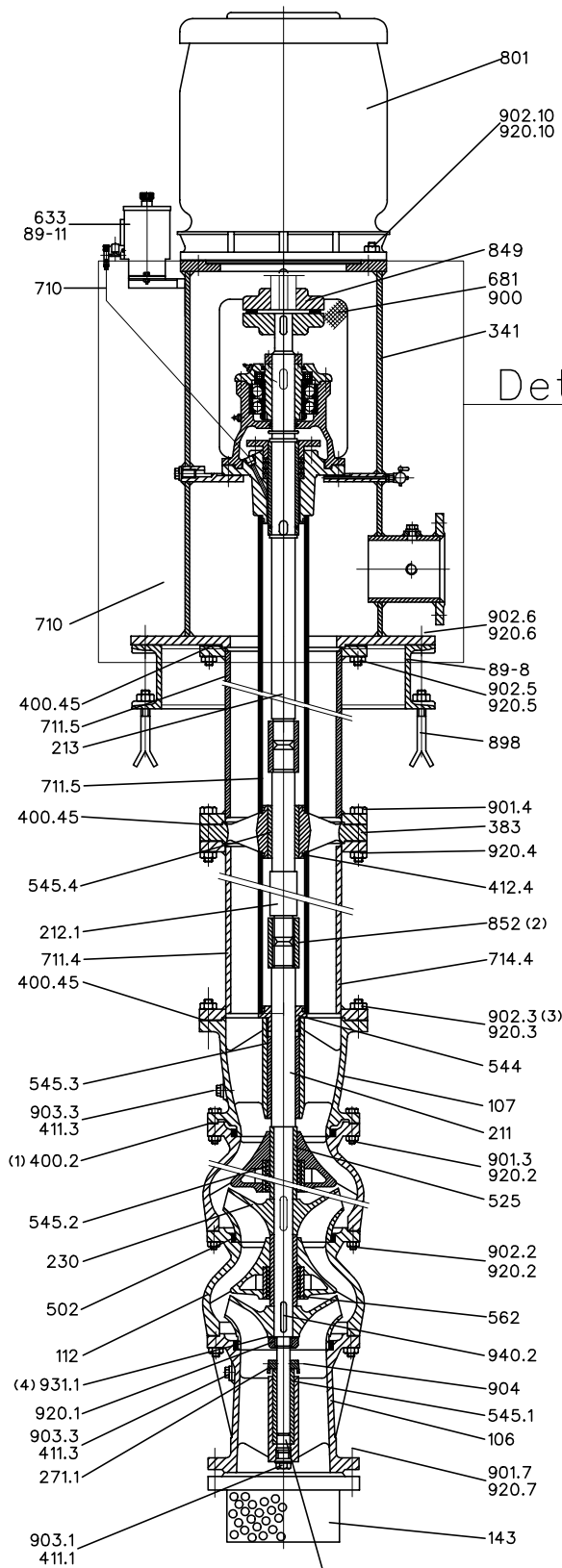

Supply with grease before
to fix the threaded plug 903.1

Fig. 29

21.4 External source water lubricating detail

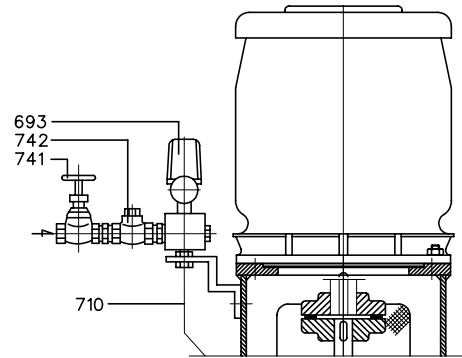

Detail X

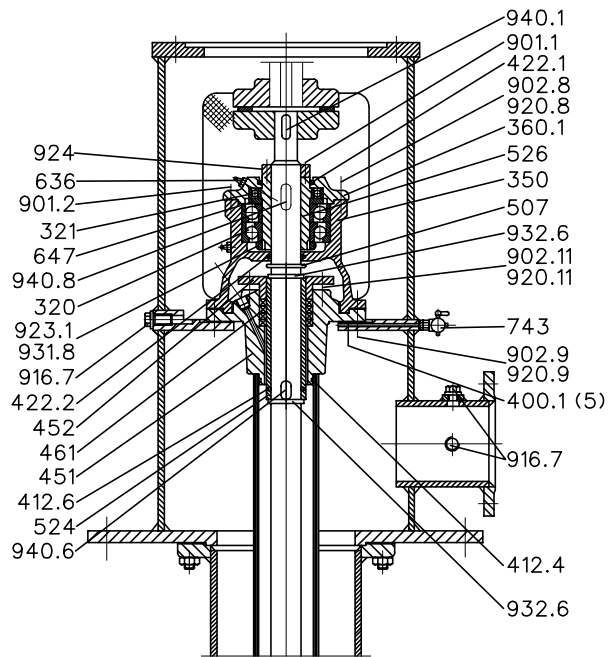

Detail X

- (1) 412.2 O'ring for pump size B22B and B24B.
- (2) 853 Split coupling for pump size B22B and B24B.
- (3) 901.31 Hexagon head bolt for pump size B12B/D, B22B and B24B.
- (4) Not applied for pump size B6B.
- (5) 412.3 O'ring for pump with bearing pedestal BUA 75.

Part no.	Denomination	Standard material ①
106	Suction case	A48CL30
107	Discharge case	A48CL30
143	Strainer (optional)	SAE 1020
112	Intermediate bowl	A48CL30
211	Pump shaft	SAE 1045
212	Column shaft	SAE 1045
213	Drive shaft	SAE 1045
230	Impeller	A48CL30
231	Suction impeller	A48CL30
271	Sand guard	TM 23
320	Angular contact ball bearing	(see table 1)
321	Deep groove ball bearing	(see table 1)
341	Drive stool	SAE 1020
350	Bearing housing	A48CL30
360	Bearing cover	A48CL30
380	Bearing part	A48CL30
383	Bearing spider	A48CL30
400	Flat gasket	Hydraulic gasket
411	Sealing ring	Copper
412	O-ring	Rubber
421	Radial seal ring	Steel / Rubber
422	Felt ring	Feltro
452	Stuffing box cover	A48CL30
461	Stuffing box packing	Aramid & graphite
502	Casing wear ring	A48CL30
507	Deflector	Buna N *
524	Shaft protecting sleeve	AISI 420
525	Spacer sleeve	TM 23
526	Centering sleeve	SAE 1045
544	Threaded bush	TM 23
545	Bearing bush	TM 23
562	Cylindrical pin	SAE 1020
565	Rivet	AISI 302
633	Oil lubricator	---
636	Grease nipple	Galvanized steel
647	Grease regulator	SAE 1020
681	Coupling guard	SAE 1020
693 ③	Pressostato	---
710	Lubricating pipe	Steel
711	Column pipe	(see note 2)
714	Shaft enclosing tube	ASTM A53 GR.B (without seam)
741 ③	Shut off valve	Brass
742 ③	Non return valve	Brass
801	Flange motor	---
849	Coupling	---
852	Threaded coupling	AISI 420
89-8	Foundation rail	SAE 1020
89-11	Angular support	SAE 1020
898	Anchor bolt	SAE 1020
900	Bolt	SAE 1020
901	Hexagon head bolt	SAE 1020
902	Stud	SAE 1020
903	Threaded plug	SAE 1020
904	Threaded pin	Steel
916	Threaded plug	Steel
920	Nut	SAE 1020
923	Bearing nut	Aço
924	Adjusting nut	SAE 1045
931	Lockwasher	SAE 1045
932	Circlip	Spring steel
940	Key	SAE 1045
970	Plate	AISI 302

Notes:

①-Other materials under consult

②-SCH 40 ASTM A106GR.A (seamless): For B 18, B 20 and B 24 – SAE 1020 (with seam)

③-Applicable only for external source lubrication

* AISI 316 for BUA 75

21.5 Discharge head with hollow shaft motor and without shaft enclosing tube

Part no.	Denomination	Standard material ①
10-1	Discharge head	A48CL30
213	Drive shaft	SAE 1045
380	Bearing part	A48CL30
400	Flat gasket	Hydraulic gasket
451	Stuffing box housing	A48CL30
452	Stuffing box cover	A48CL30
461	Stuffing box packing	Aramid & graphite
524	Shaft protecting sleeve	TM 23
720	Connection	Steel
730	Pipe junction	Steel
731	Pipe union	Steel
743	Valve	Brass
803	Hollow shaft motor	---
901	Hexagon head bolt	SAE 1020
902	Stud	SAE 1020
903	Threaded plug	SAE 1020
920	Nut	SAE 1020
924	Adjusting nut	SAE 1045
932	Circlip	Spring steel
940	Key	SAE 1045

NOTE:

① - Other materials under consult.

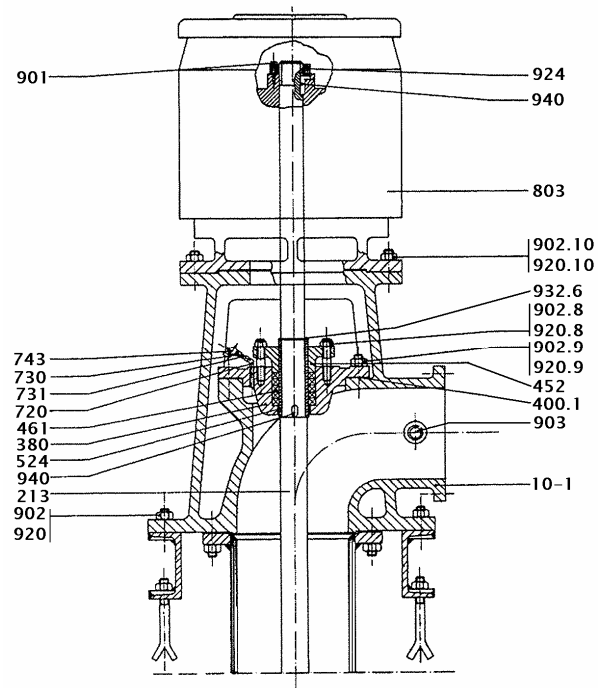

21.6 Discharge head with hollow shaft motor and with shaft enclosing tube

Part no.	Denomination	Standard material ①
10-1	Discharge head	A48CL30
213	Drive shaft	SAE 1045
380	Mancal part	A48CL30
400	Flat gasket	Hydraulic gasket
421	Radial seal ring	Steel / rubber
545	Bearing bush	TM 23
562	Cylindrical pin	SAE 1020
707	Lubricating pipe	Steel
714	Shaft enclosing tube	ASTM A 53GR.B (without seam)
731	Pipe union	Steel
803	Hollow shaft motor	---
901	Hexagon head bolt	SAE 1020
902	Stud	SAE 1020
903	Threaded plug	SAE 1020
920	Nut	SAE 1020
924	Adjusting nut	SAE 1045

NOTE:

① - Other materials under consult.

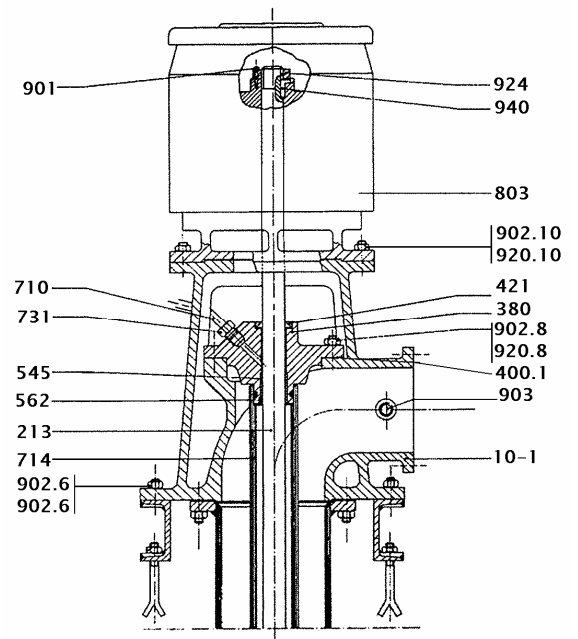

21.7 Split (muff) coupling for B22B and B24B

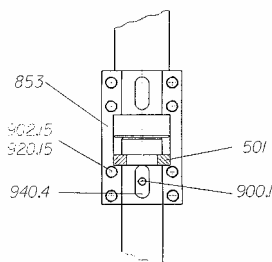

Part no.	Denomination	Standard material ①
501	Split ring	AISI 304
853	Split coupling	AISI 304
900.1	Threaded pin	Inox 304
902.1	Stud	AISI 304
920.1	Nut	AISI 304
940.4	Key	SAE 1045

B 6 B

3480 rpm

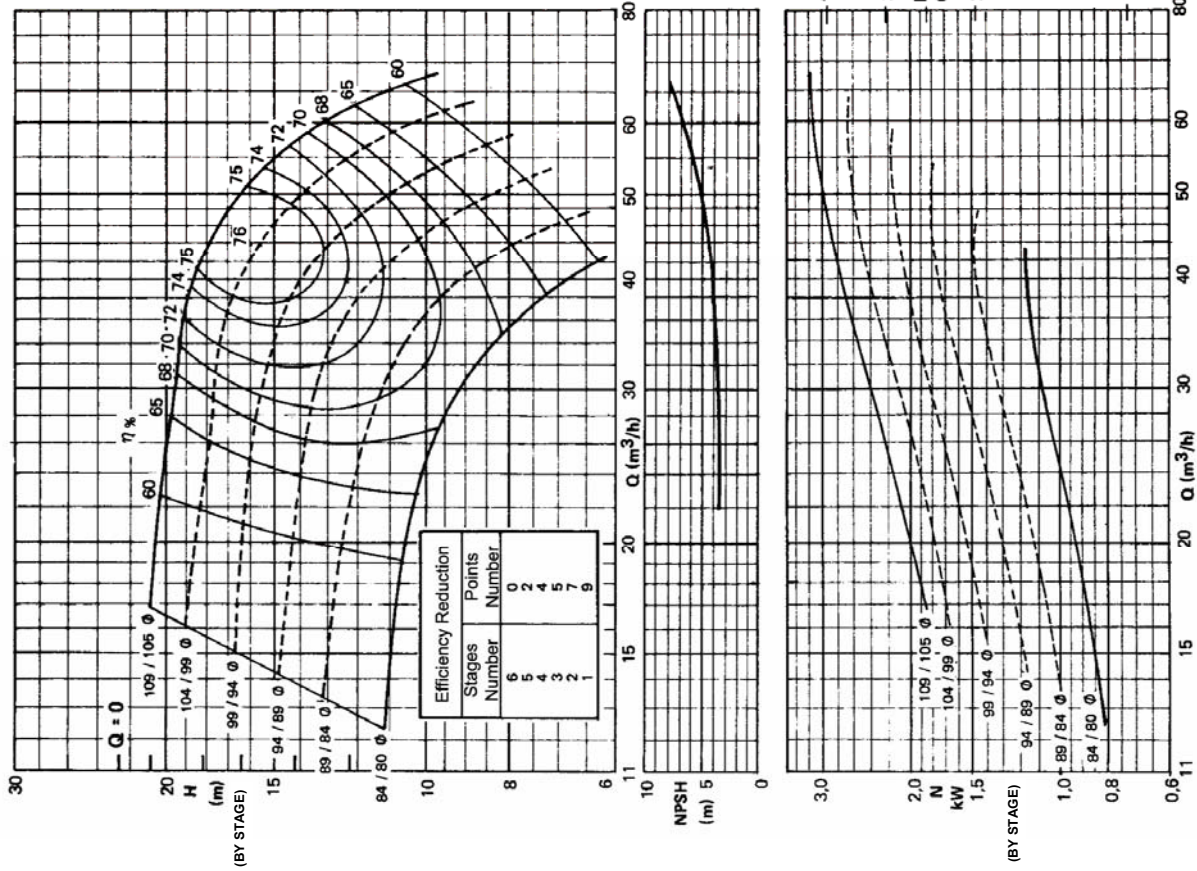

B 7 B

NPSH values are measurement values.
Please add 0,5 m for safety.

3480 rpm

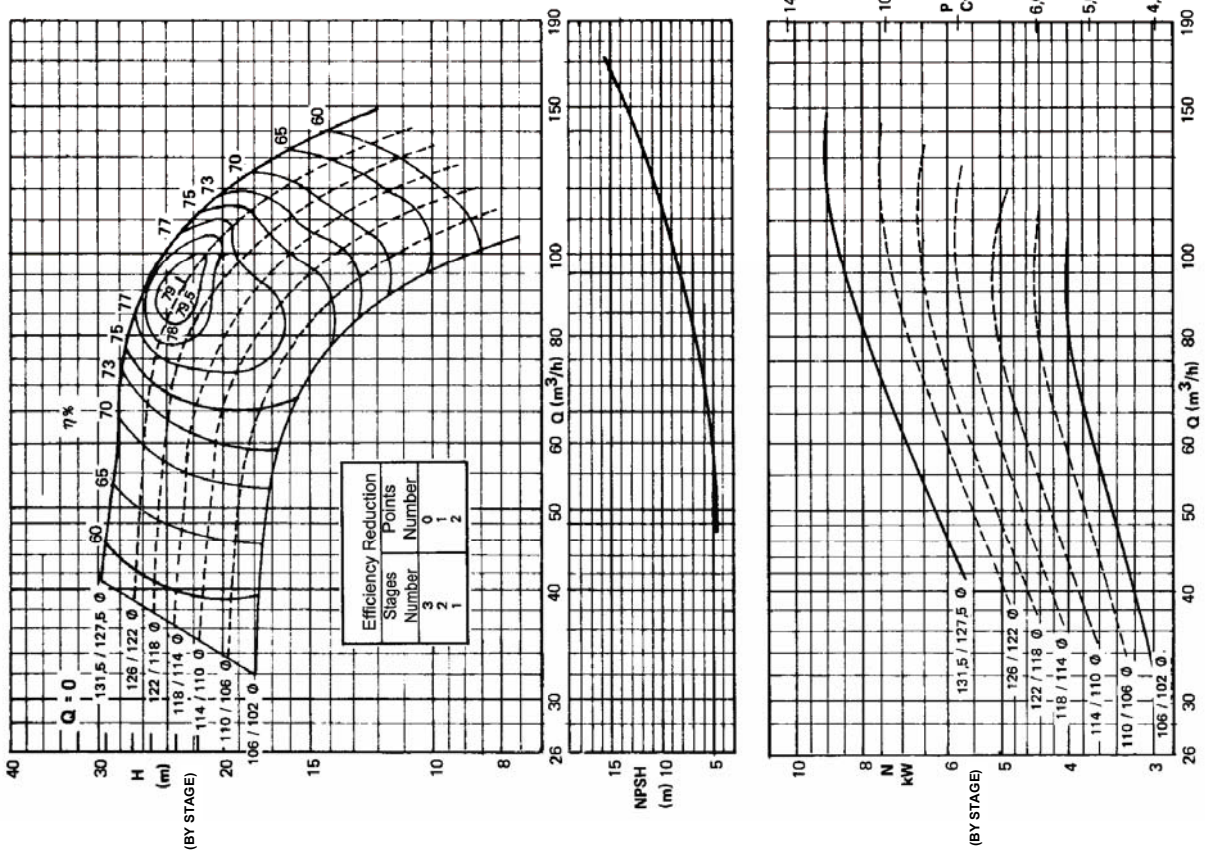

B 8 B

3480 rpm

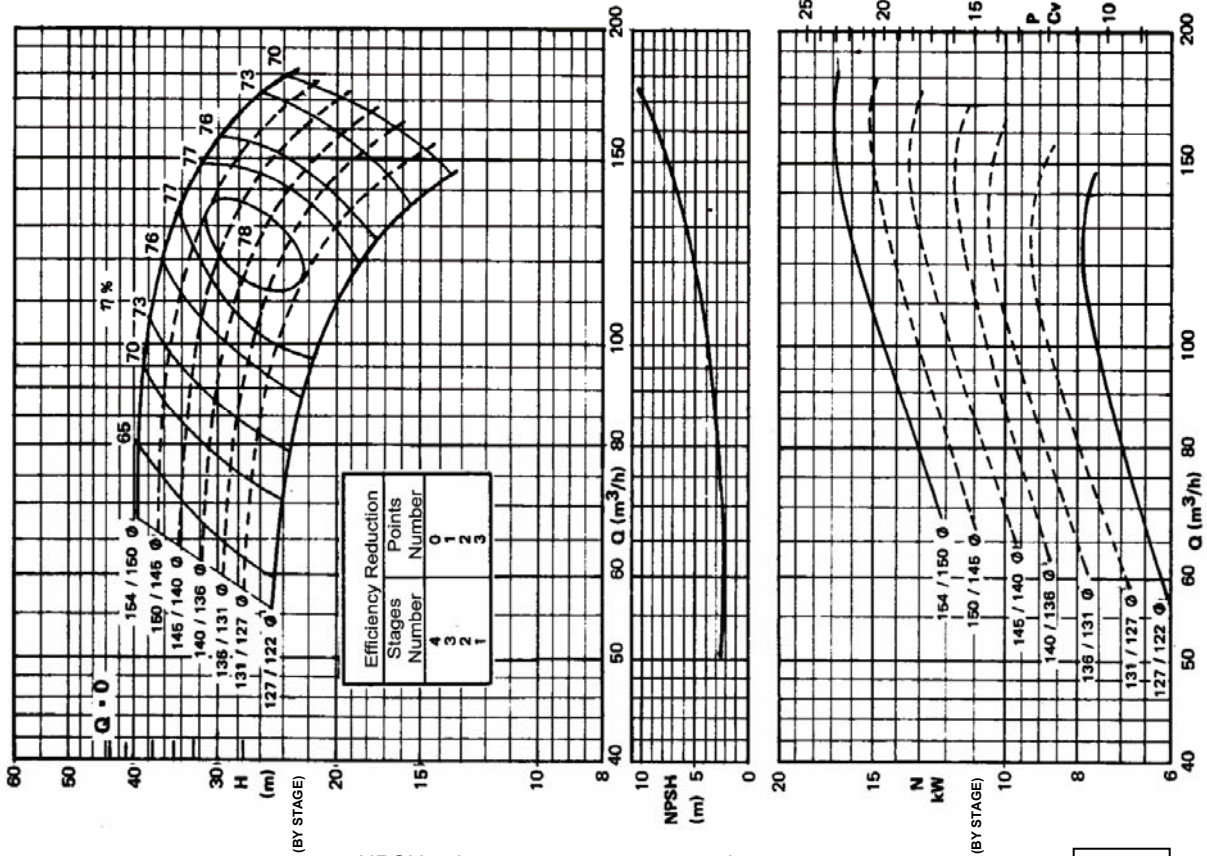

B 6 B

1740 rpm

NPSH values are measurement values.
Please add 0,5 m for safety.

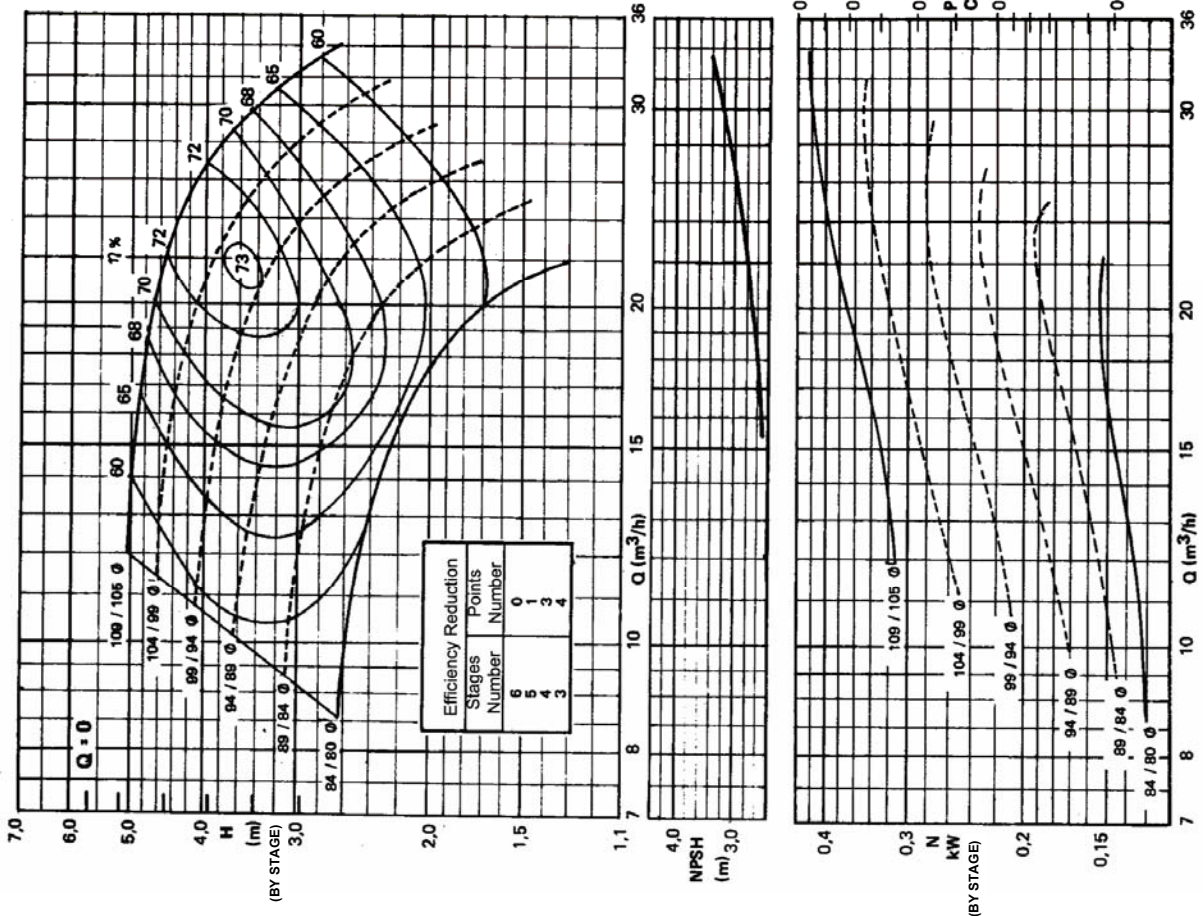

B 7 B

1740 rpm

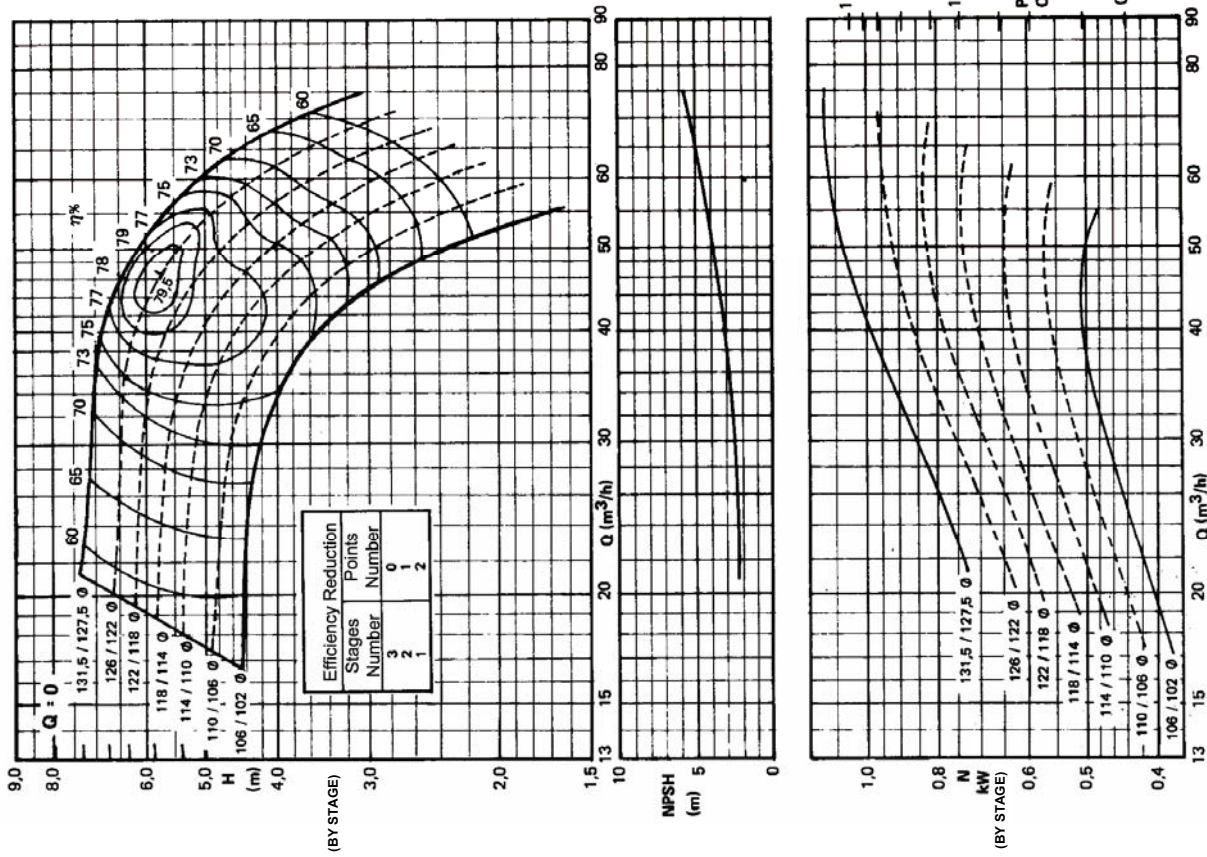

B 8 B

NPSH values are measurement values.
Please add 0,5 m for safety.

1740 rpm

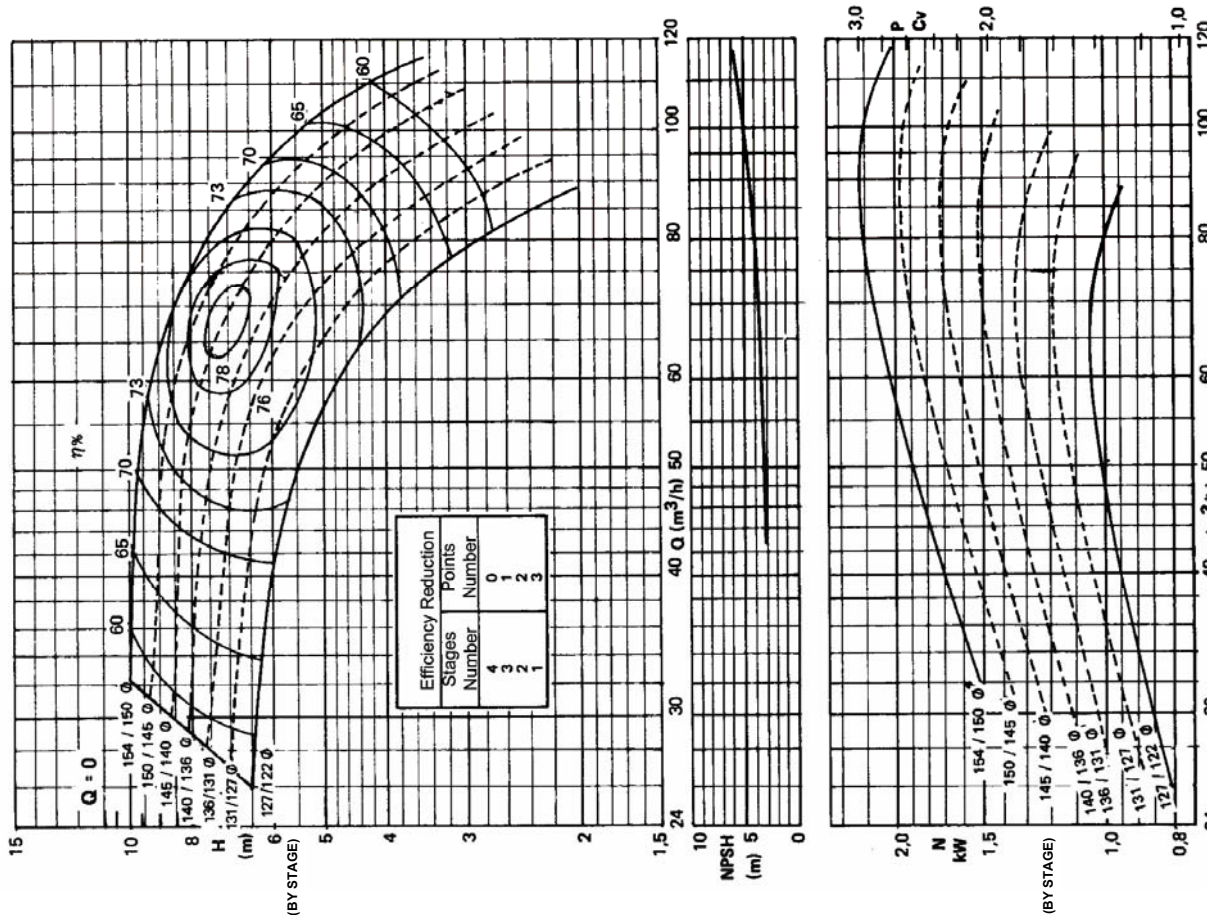

B 10 B

1740 rpm

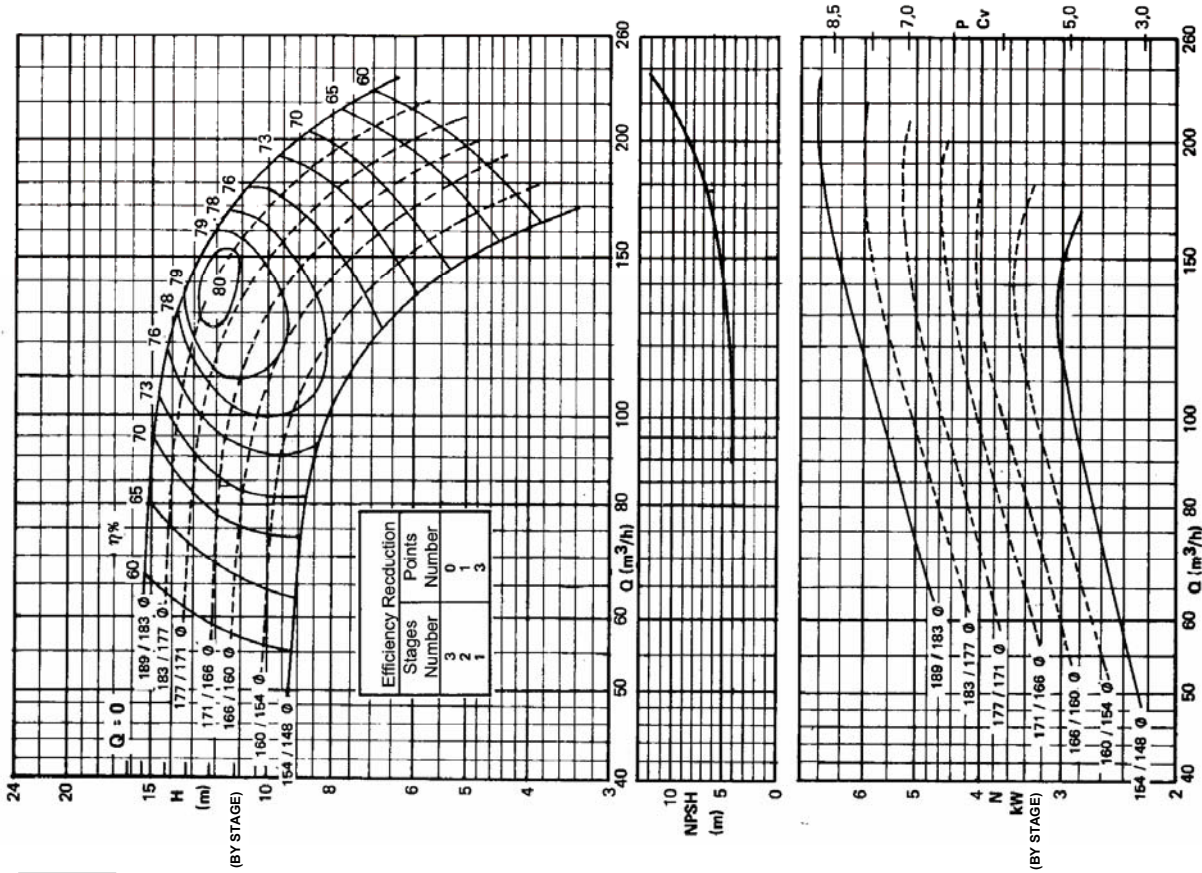

B 10 D

NPSH values are measurement values.
Please add 0,5 m for safety.

1740 rpm

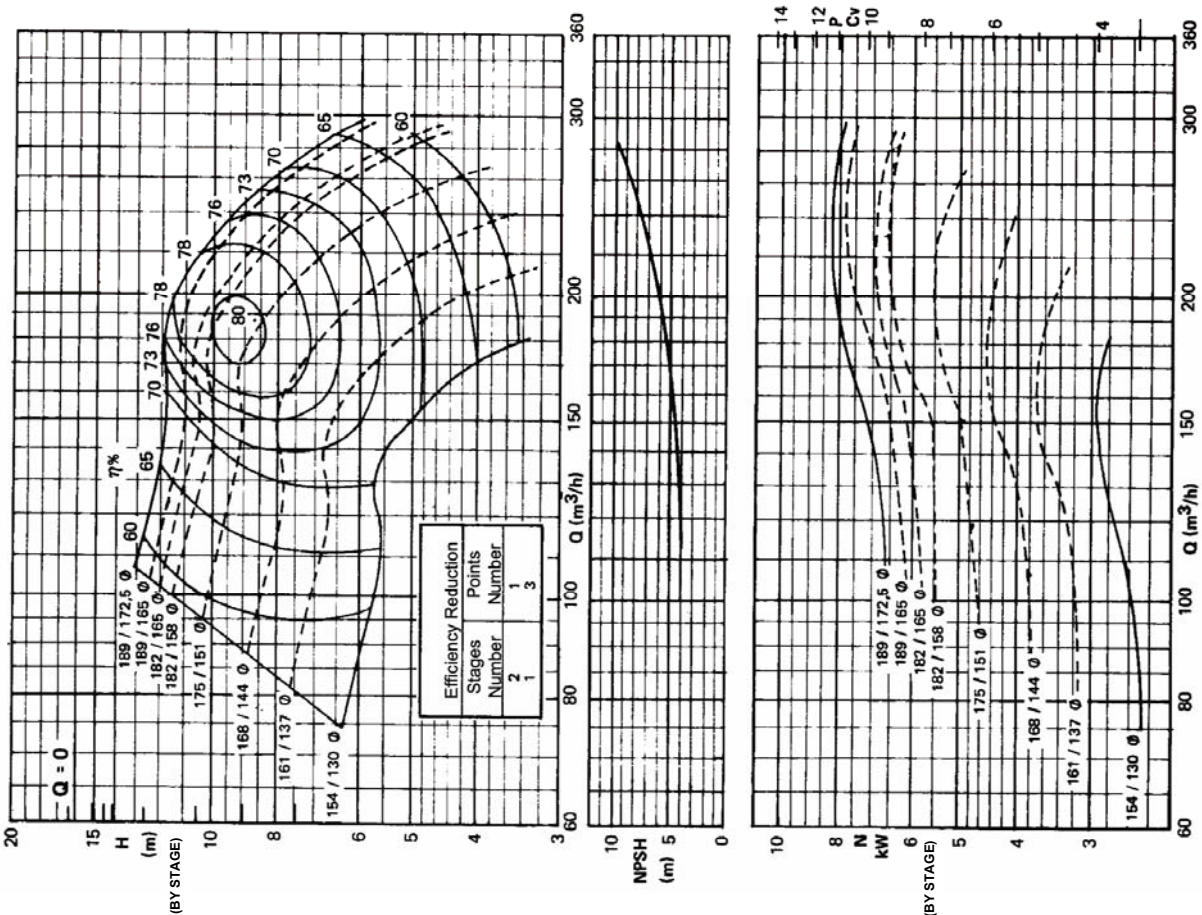

B 12 B

1740 rpm

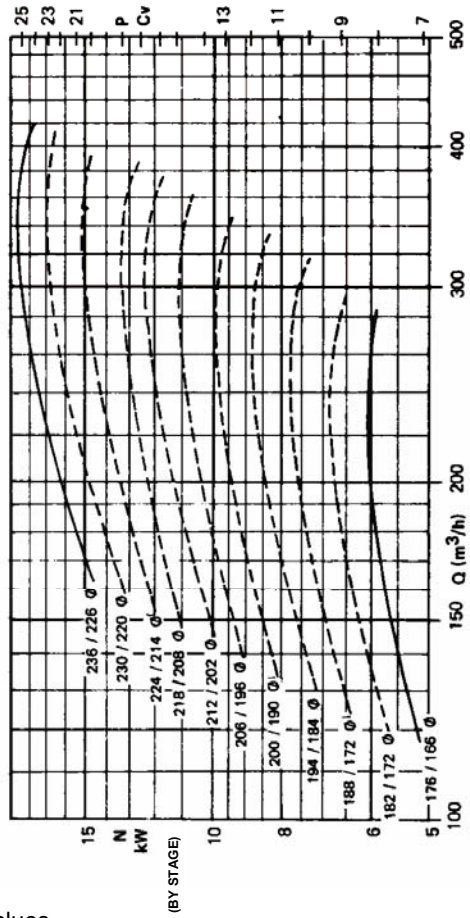
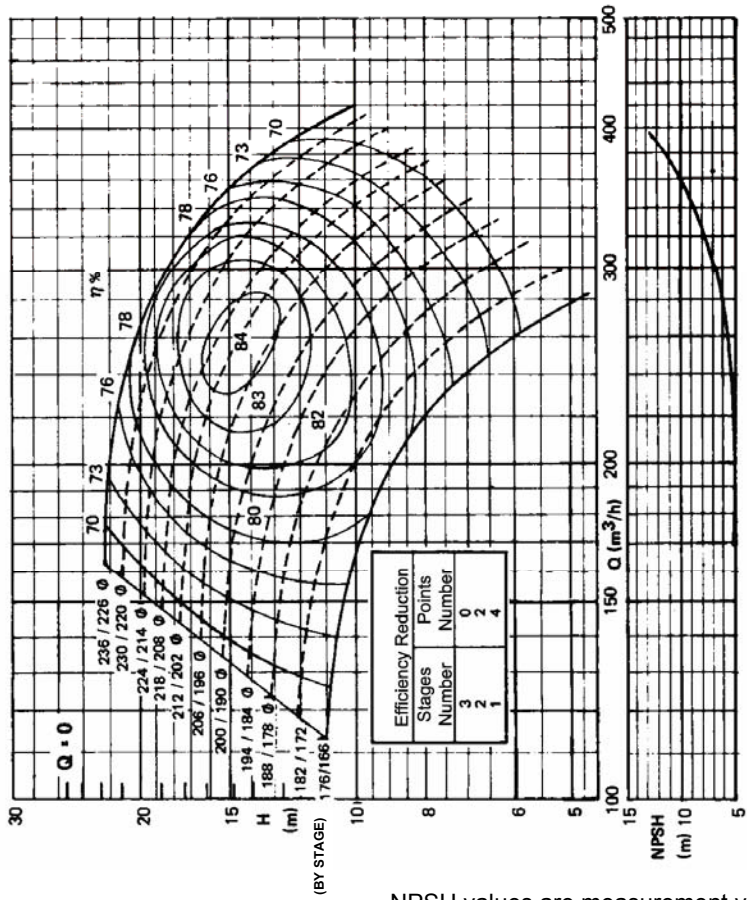

NPSH values are measurement values.
Please add 0,5 m for safety.

B 12 D

1740 rpm

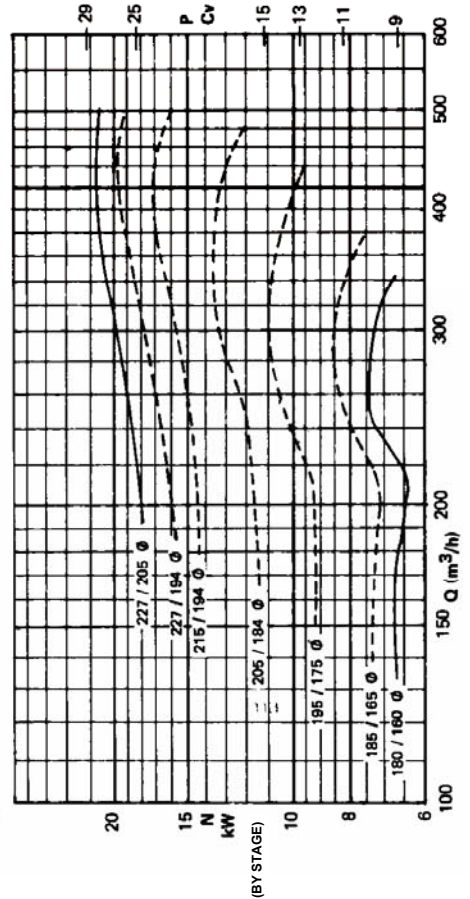
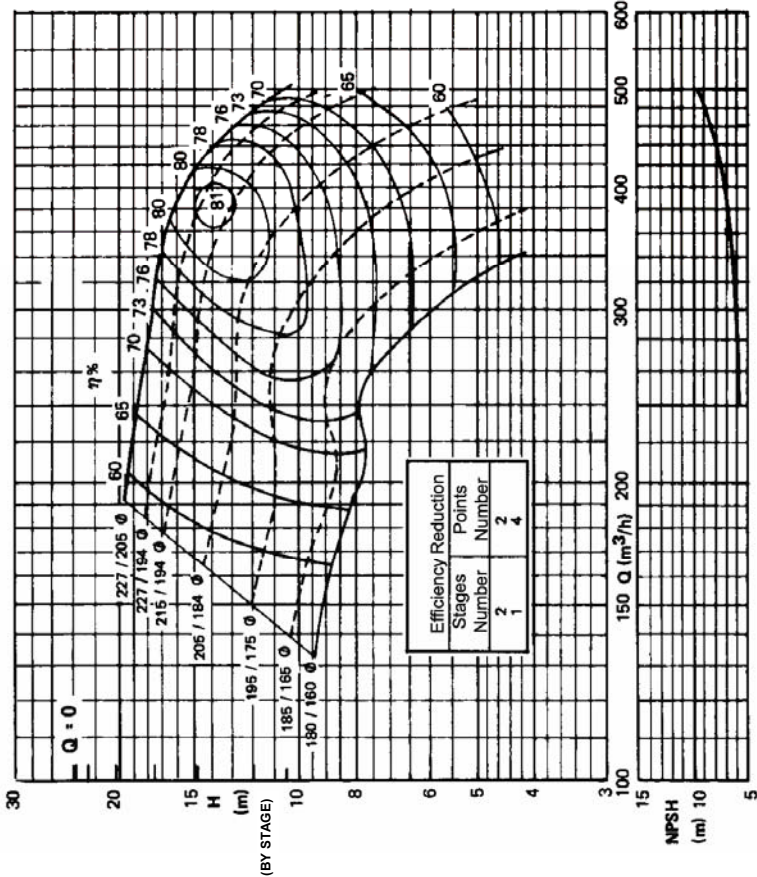

B 14 B

1740 rpm

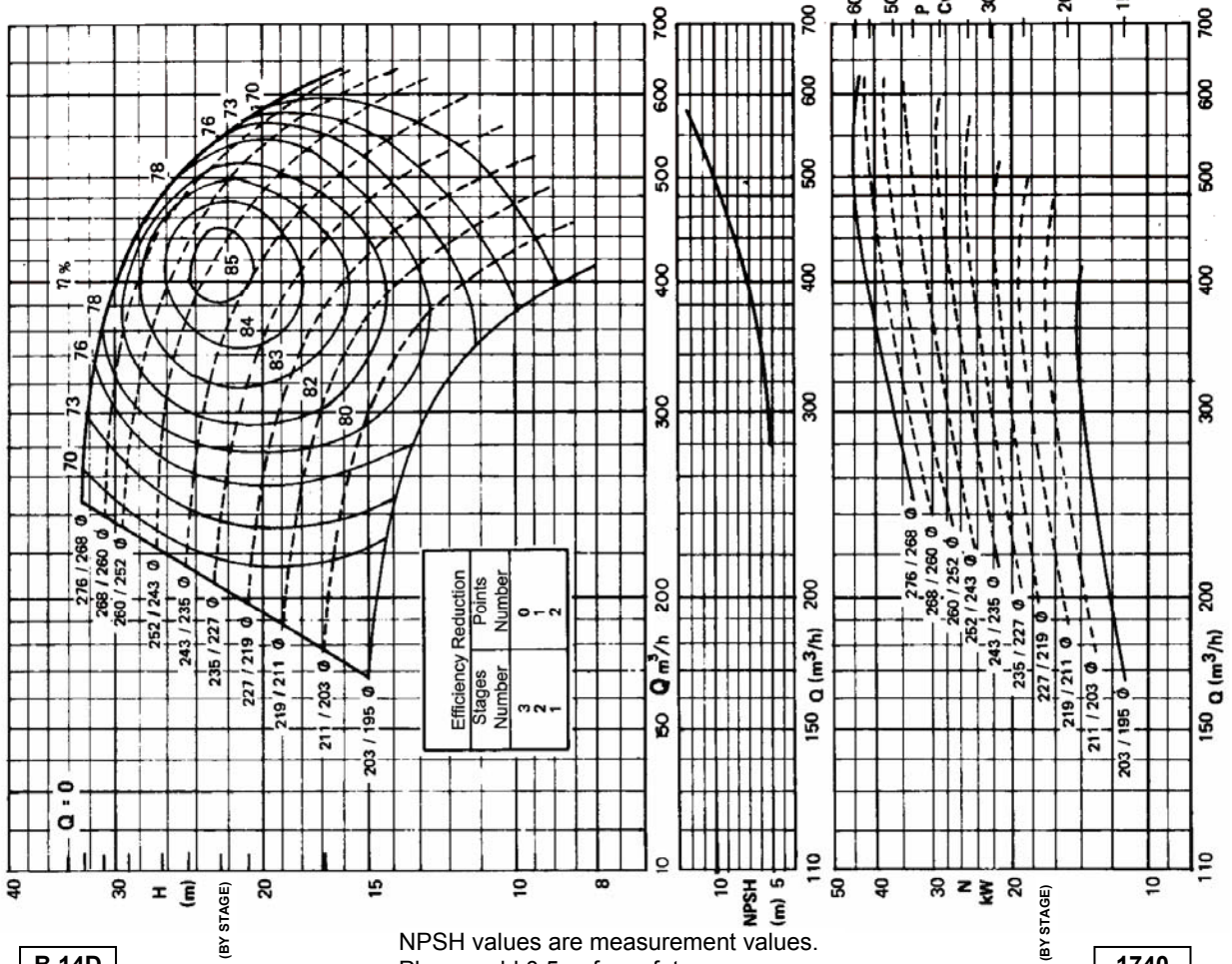

B 14 D

1740 rpm

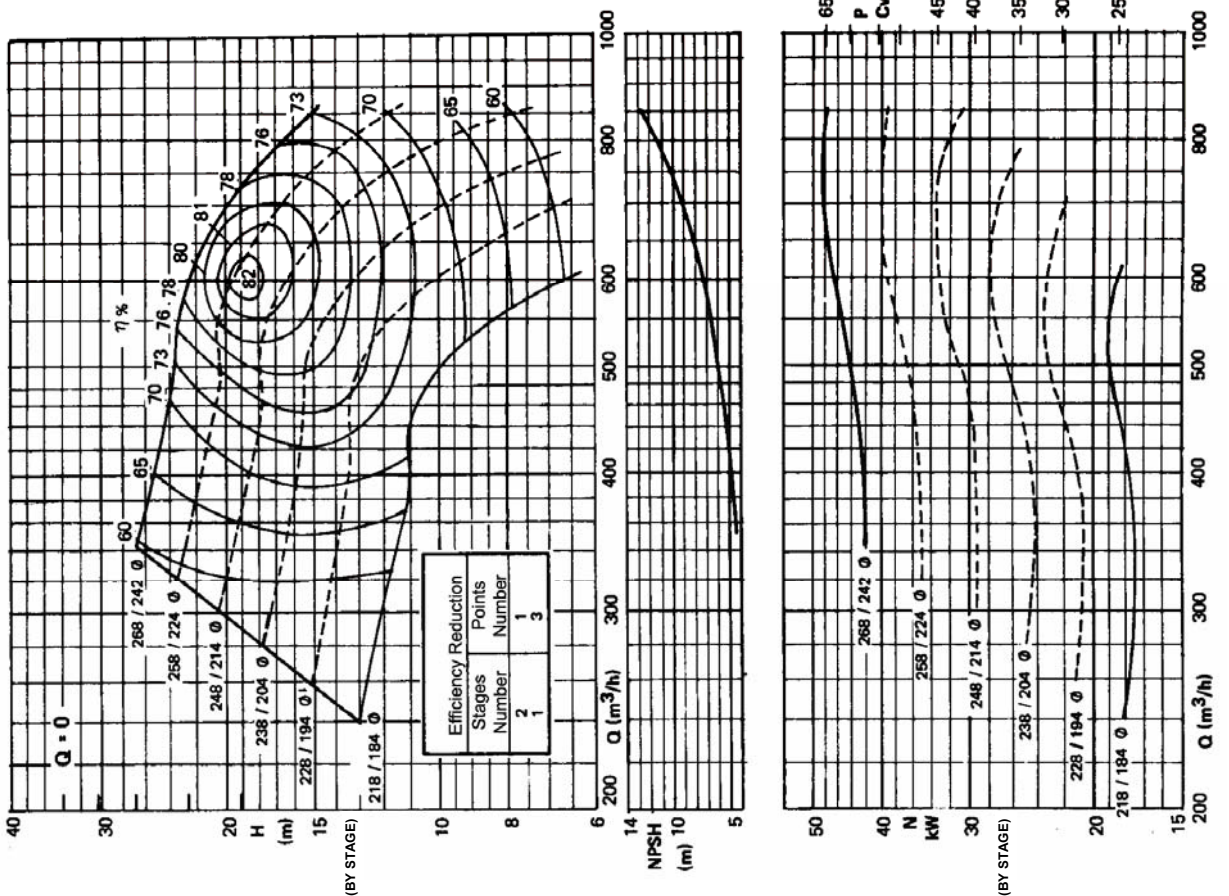

B 16 B

1740 rpm

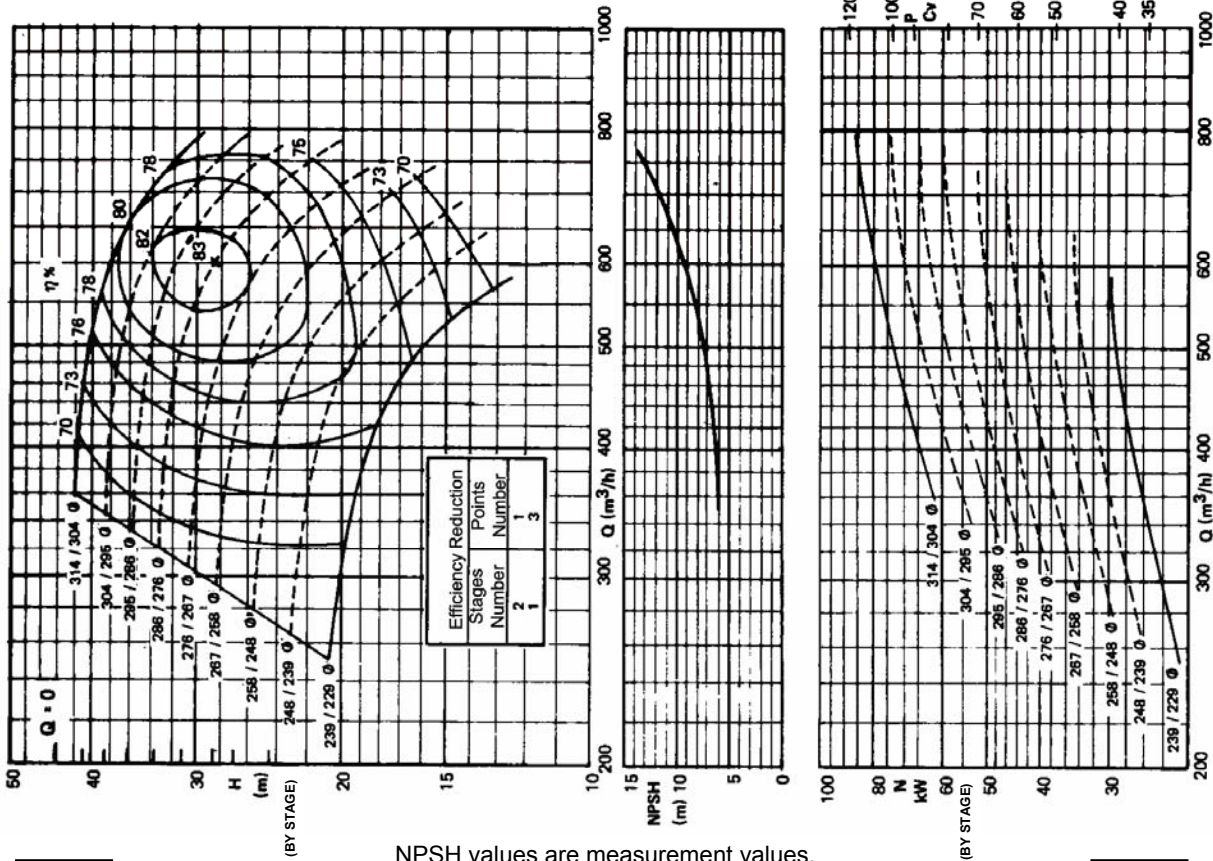

NPSH values are measurement values.
Please add 0,5 m for safety.

B 16 D

1740 rpm

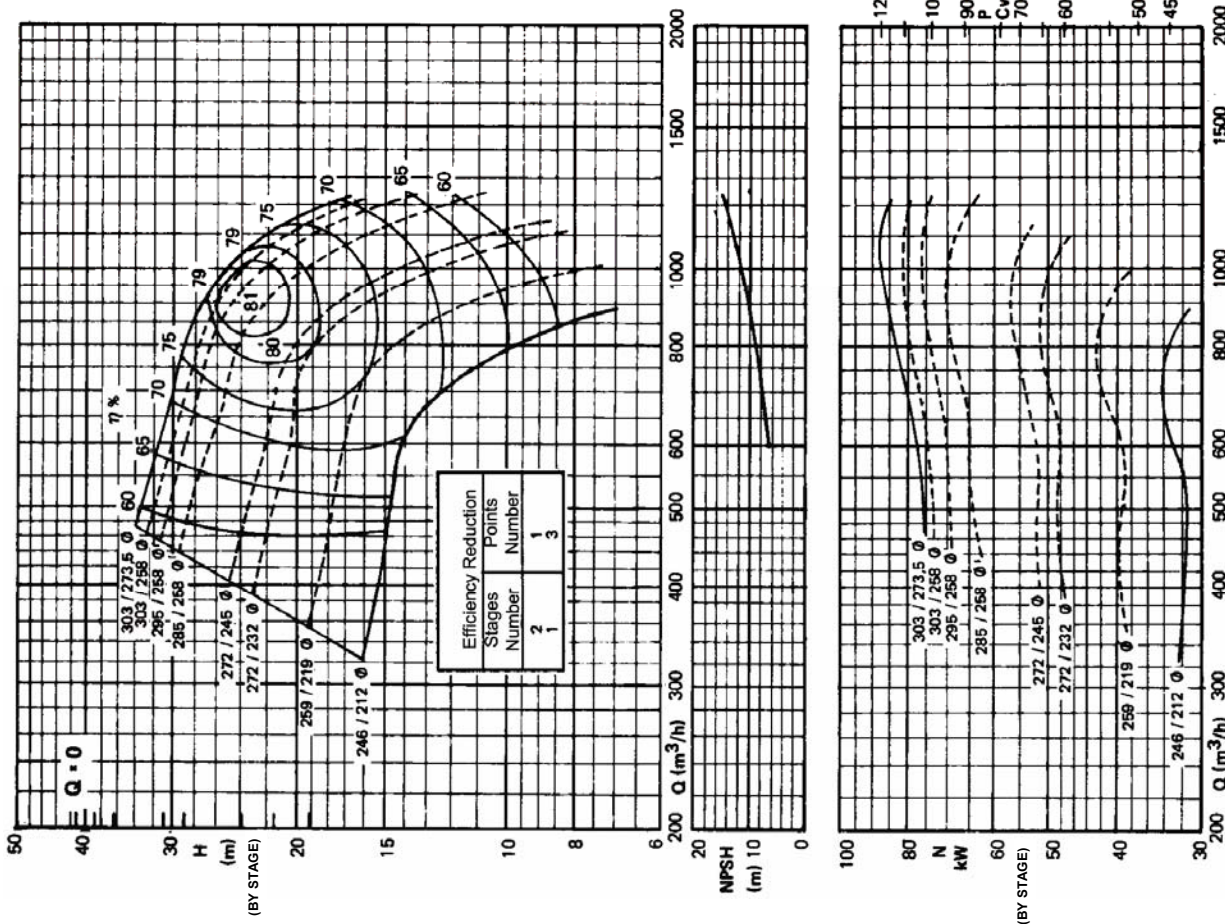

B 18 B

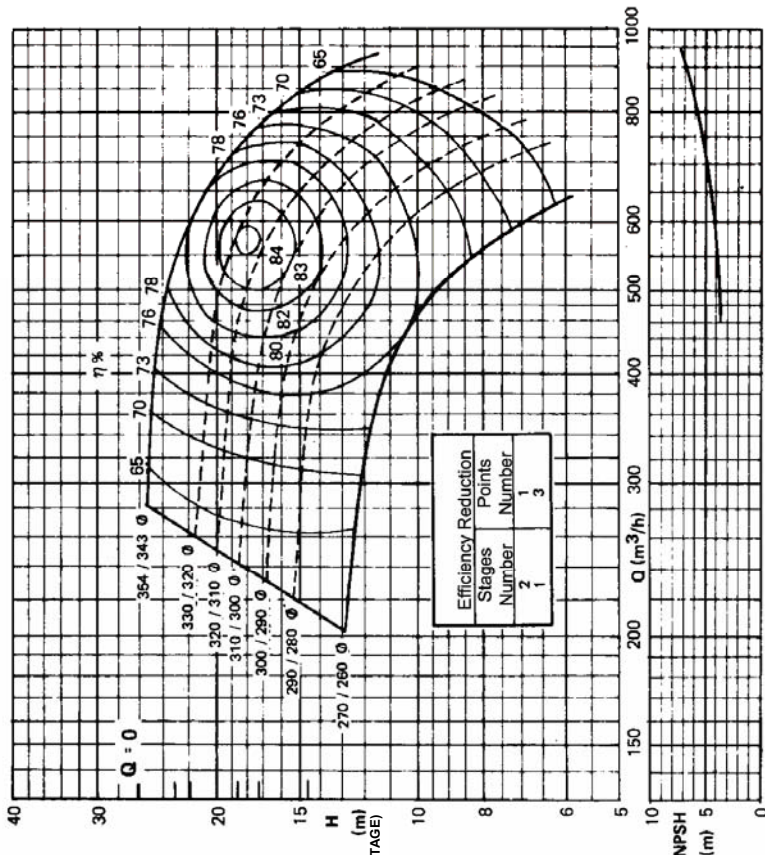

1160

rpm

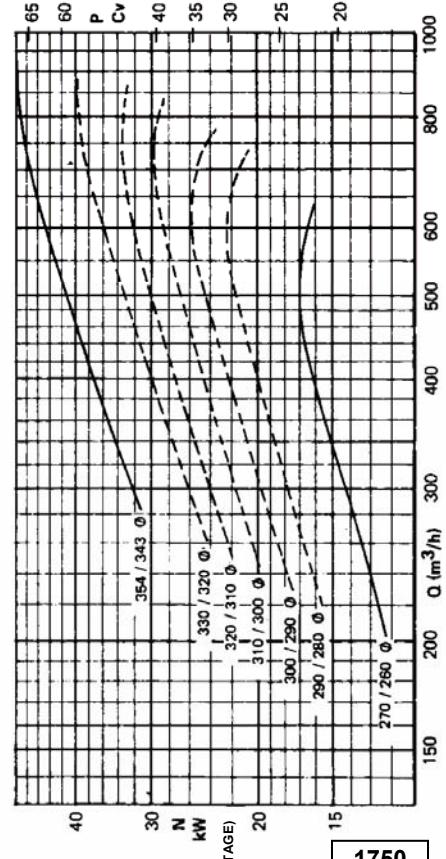

B 18 D

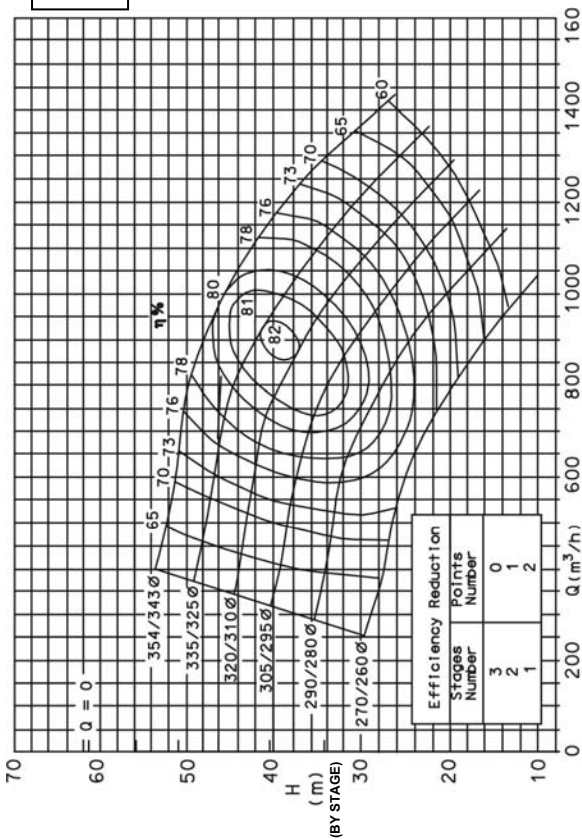

NPSH values are measurement values.
Please add 0,5 m for safety.

1750

rpm

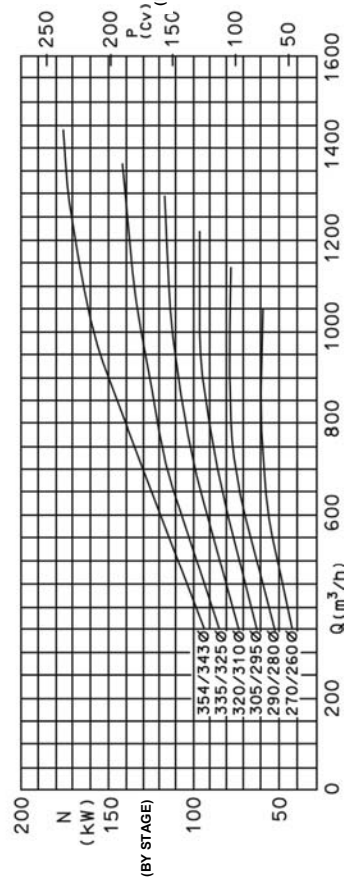
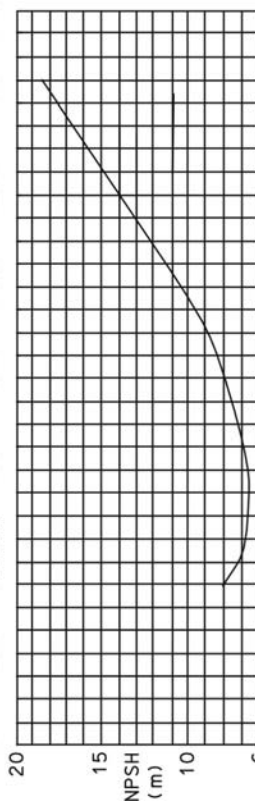

B 20 B

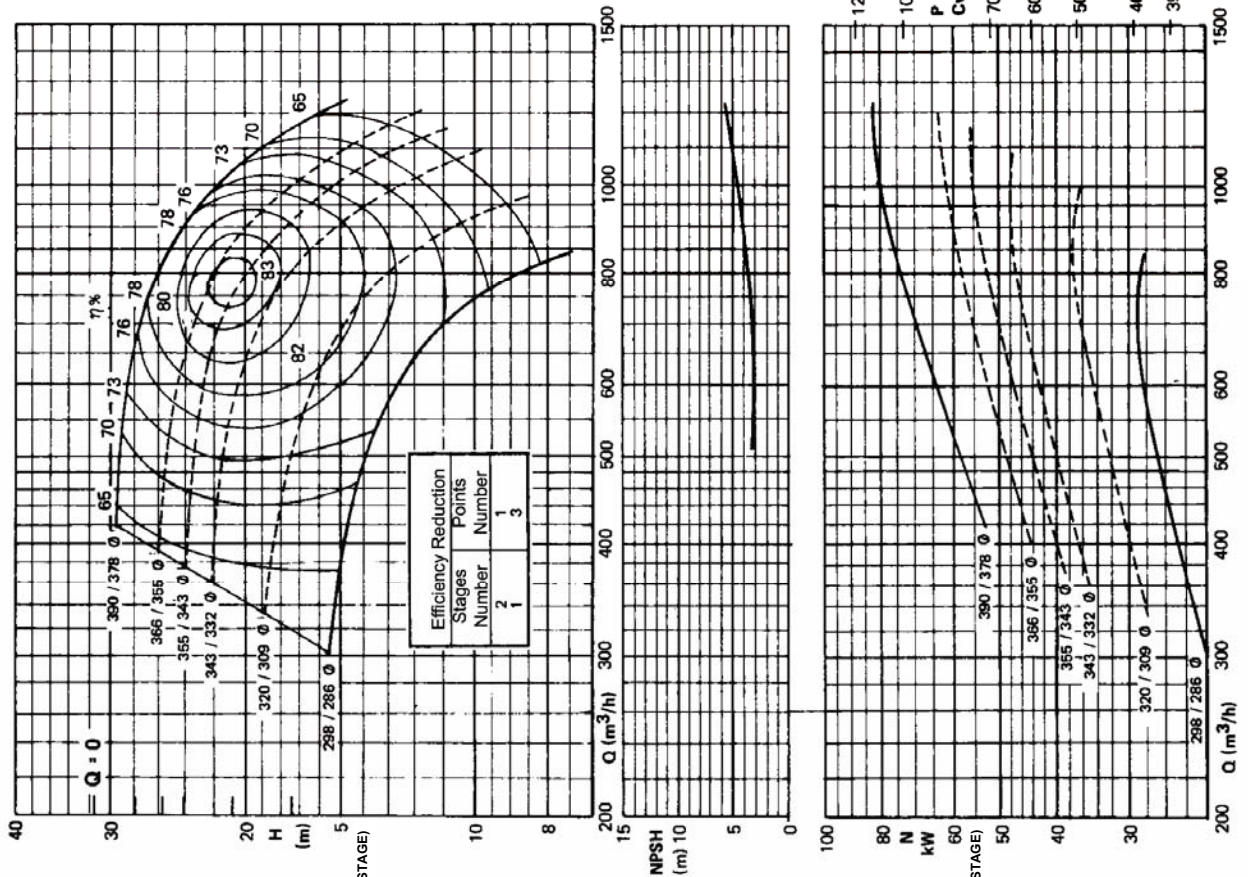

B 22 B

NPSH values are measurement values.
Please add 0,5 m for safety.

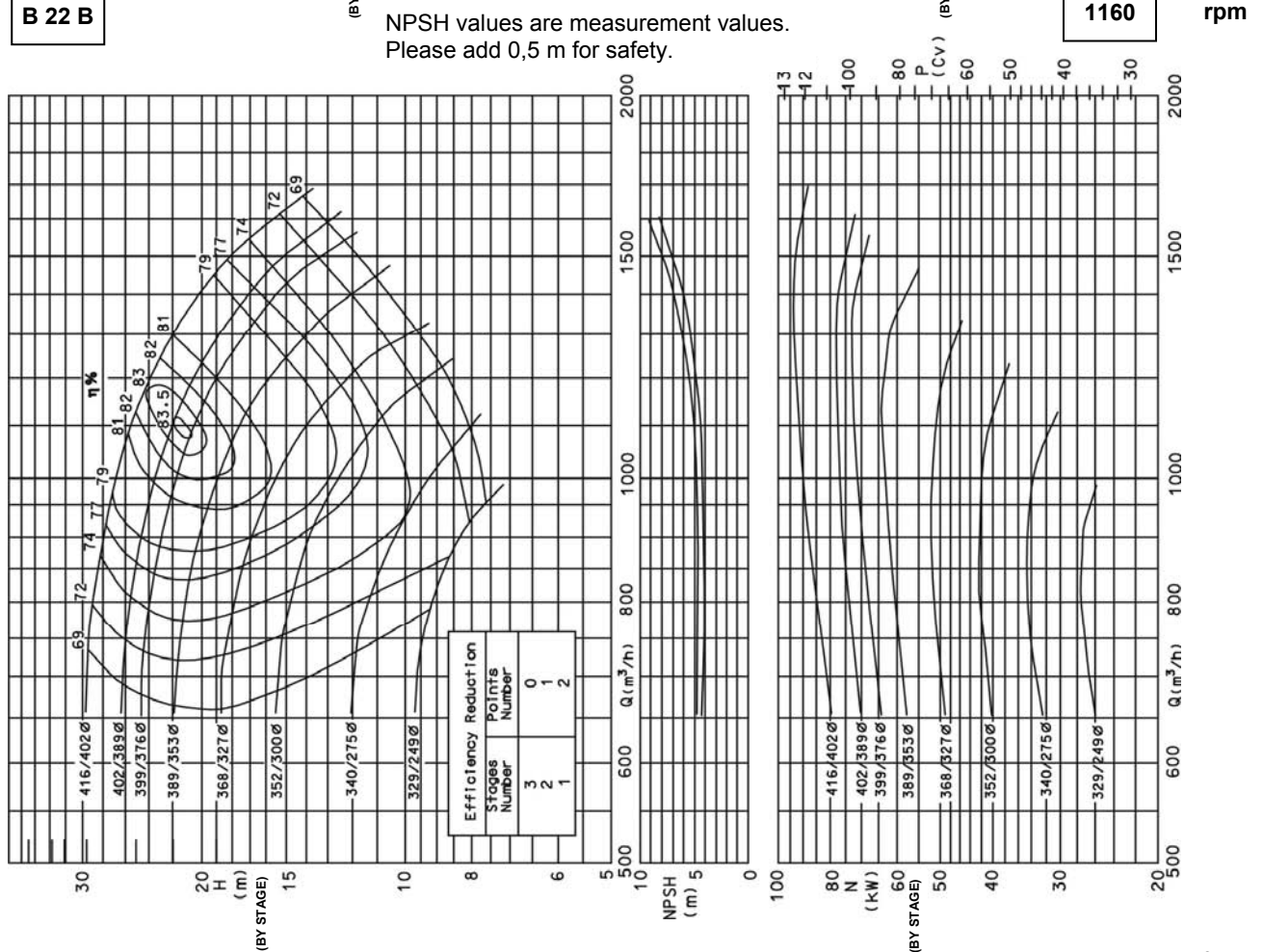

B 24 B

1160 rpm

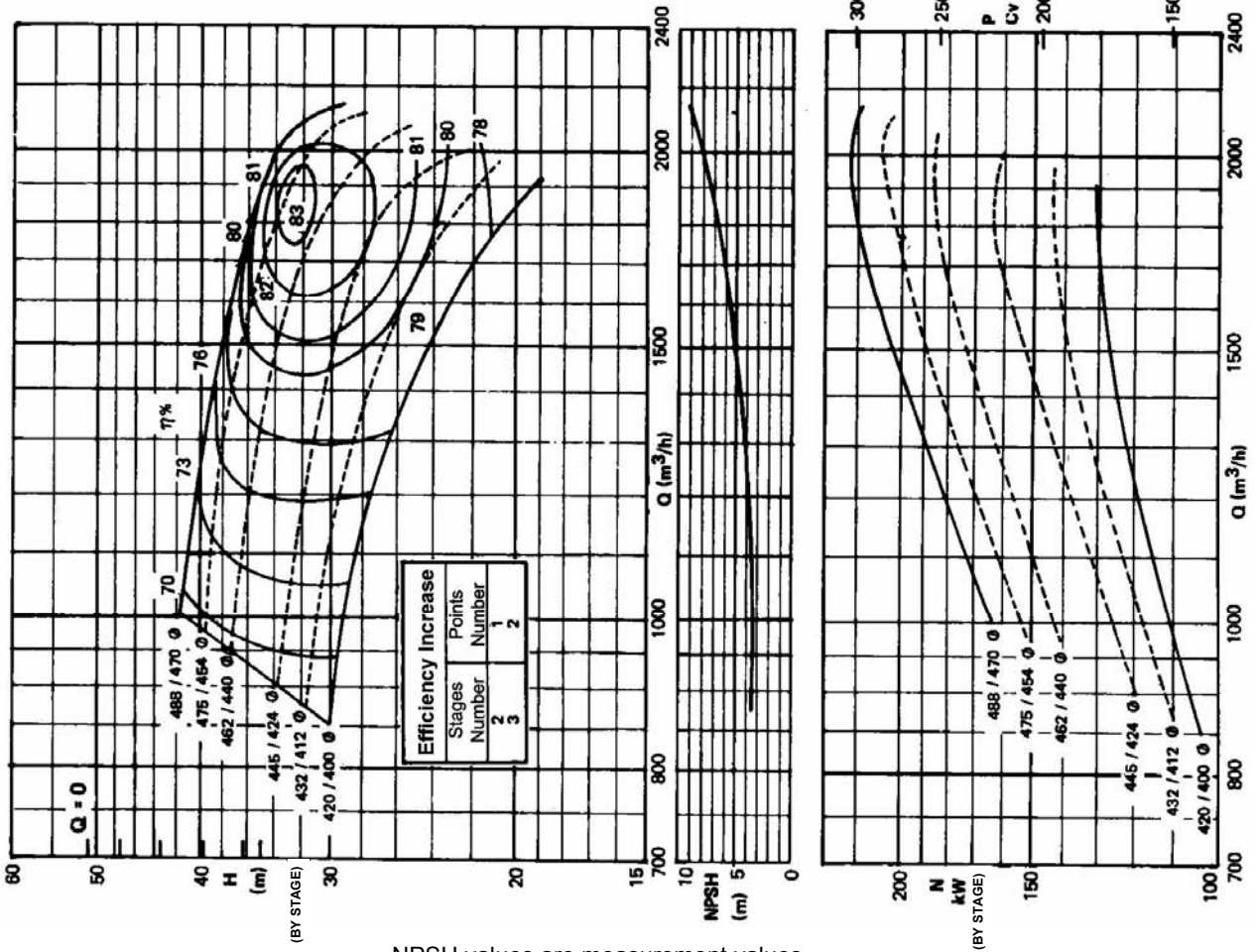

NPSH values are measurement values.
Please add 0,5 m for safety.

27.06.2007

A3210.0E/1

KSB Bombas Hidráulicas SA
Rua José Rabello Portella, 400
Várzea Paulista SP 13220-540
Brazil <http://www.ksb.com>
Phone.: 55 11 4596 8500 Fax: 55 11 4596 8580
SAK – KSB Customer Service
e-mail: gqualidade@ksb.com.br
Fax: 55 11 4596 8656